

SPECIFICATIONS

HOUSING : High Temperature Plastic, UL 94V-O

CONTACT : Copper Alloys

VOLTAGE RATING : 100VAC

CURRENT RATING : 0.5A

CONTACT RESISTANCE : 40 m Ohm max.

INSULATION RESISTANCE : 1000M Ohm max.

DIELECTRIC STRENGTH : 500VAC/1min

OPERATION TEMPERATURE : -40°C ~ 85°C

ORDER INFORMATION:

CFP - 503 - $\frac{X}{a} \frac{2}{b} - \frac{WR}{c} - \frac{1D}{d e f}$

- a. Plating selection :
1 : 15u" Gold Plating
- b. Type selection :
2 : Type 2
- c. Color selection :
W : White
- d. Type selection :
R : Reverse Type
- e. Stand off :
1 : 2 mm
- f. Pack selection:
D : Disk Pack

VERSION & EC DESCRIPTION

DATE	VERSION	PAGE	DESCRIPTION
2005/03/29	A	22-24	Add CFP-503-X2-WR-1D Plan

GENERAL TOLERANCE	DRAW DATE	2005/03/29 H. D. LI	PART NO
.X ± 0.30	DESIGN	H. D. LI	CFP-503-X2-WR-1D
.XX ± 0.20	CHECKED	Y. M. LU	TITLE
.XXX ± 0.10	APPROVED	J. F. KANG	CF Type2 50Pin SMT Reverse Type
UNIT :mm			 宏揚精密有限公司 HOJAR PRECISION CO., LTD.

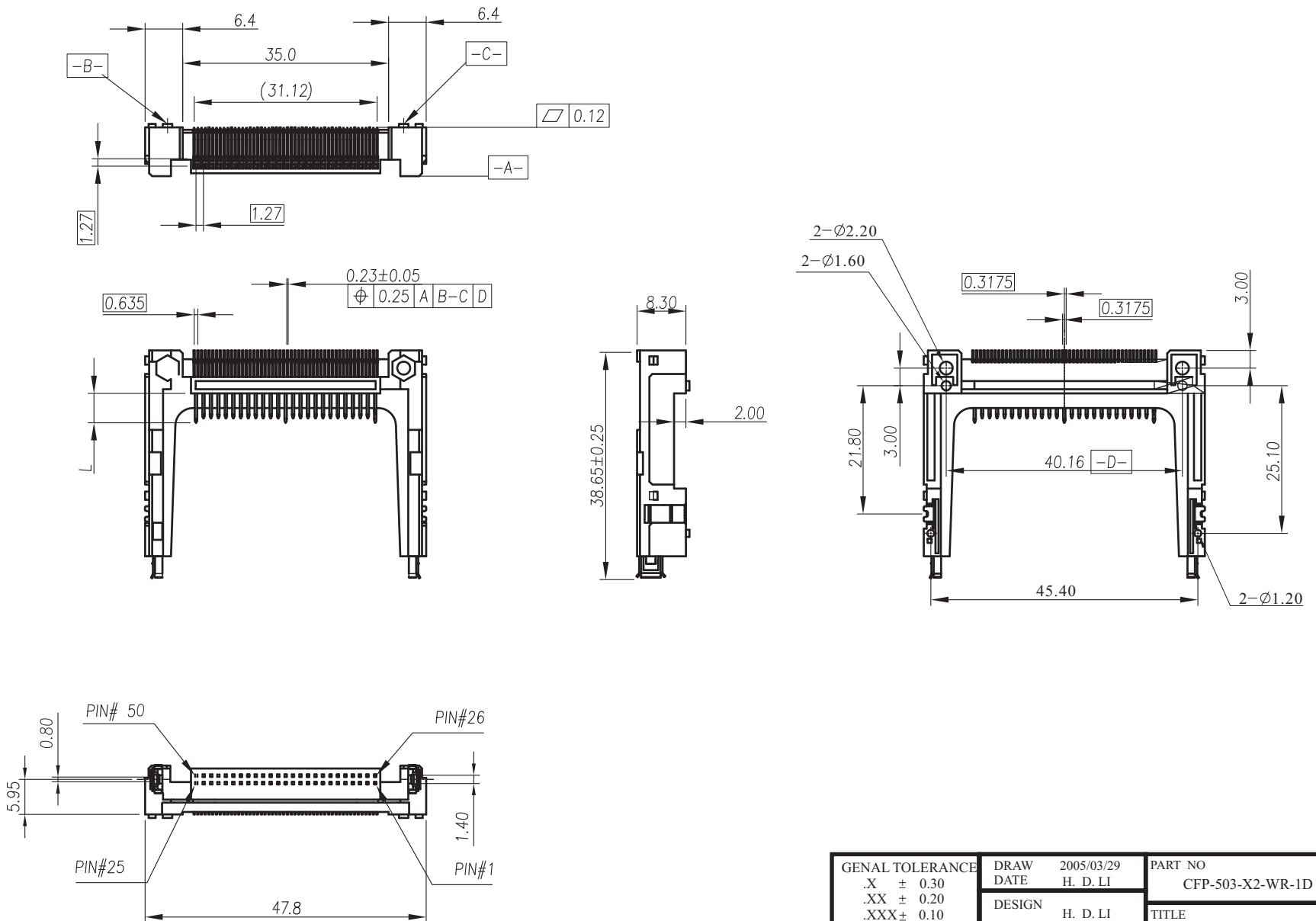

GENAL TOLERANCE .X ± 0.30 .XX ± 0.20 .XXX± 0.10	DRAW DATE	2005/03/29 H. D. LI	PART NO CFP-503-X2-WR-1D
	DESIGN	H. D. LI	TITLE CF Type2 50Pin SMT Reverse Type
	CHECKED	Y. M. LU	
	APPROVED	J. F. KANG	
UNIT :mm			 宏揚精密有限公司 HOJAR PRECISION CO., LTD.

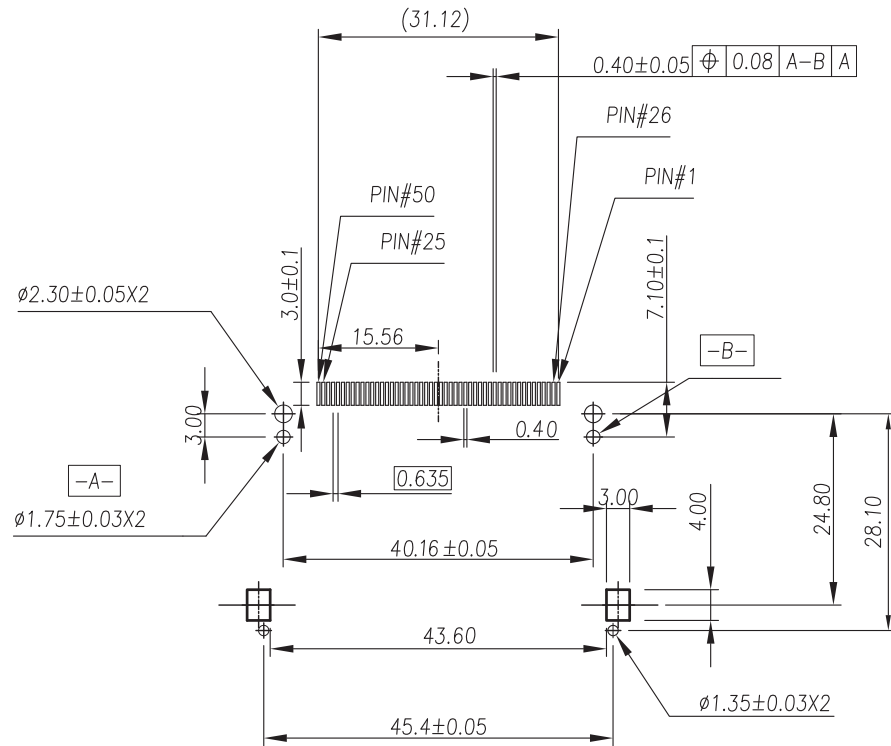

P.C.B Layout

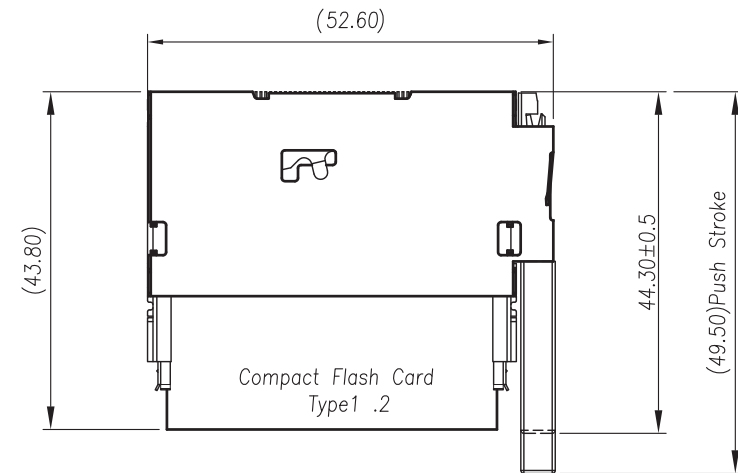

Header With Ejector

GENAL TOLERANCE .X ± 0.30 .XX ± 0.20 .XXX ± 0.10	DRAW 2005/03/29 DATE H. D. LI	PART NO CFP-503-X2-WR-1D
	DESIGN H. D. LI	TITLE CF Type2 50Pin SMT Reverse Type
	CHECKED Y. M. LU	
	APPROVED J. F. KANG	
UNIT :mm		 宏揚精密有限公司 HOJAR PRECISION CO., LTD.