

SPECIFICATIONS

HOUSING : High Temperature Plastic, UL 94V-O

CONTACT : Copper Alloys

VOLTAGE RATING : 100VAC

CURRENT RATING : 0.5A

CONTACT RESISTANCE : 40 m Ohm max.

INSULATION RESISTANCE : 1000M Ohm min.

DIELECTRIC STRENGTH : 500VAC/1min

OPERATION TEMPERATURE : -40°C ~ 85°C

ORDER INFORMATION:

CFP - 503 - $\frac{X}{a} \frac{X}{b} \frac{2}{c} - \frac{W}{d} \frac{N}{e} - \frac{0}{f} \frac{D}{g}$

- a.
 - O : Tin/Lead 90/10
 - T : Lead Free Tin 100%
- b. Plating selection :
 - 1 : 15u" Gold Plating
- c. Type selection :
 - 2 : Type 2
- d. Color selection :
 - W : White
- e. Type selection :
 - N : Normal Type
- f. Stand off :
 - 0 : 0 mm
- g. Pack selection:
 - D : Disk Pack

VERSION & EC DESCRIPTION			
DATE	VERSION	PAGE	DESCRIPTION
2005/03/25	A	13-15	Add CFP-503-X2-WN-0D Plan

GENERAL TOLERANCE .X ± 0.30 .XX ± 0.20 .XXX ± 0.10	DRAW DATE	2005/03/25 H. D. LI	PART NO	CFP-503-XX2-WN-0D
	DESIGN	H. D. LI	TITLE	CF Type2 50Pin SMT Normal Type
	CHECKED	Y. M. LU		
	APPROVED	J. F. KANG		
UNIT :mm				 宏揚精密有限公司 HOJAR PRECISION CO., LTD.

VERSION

A

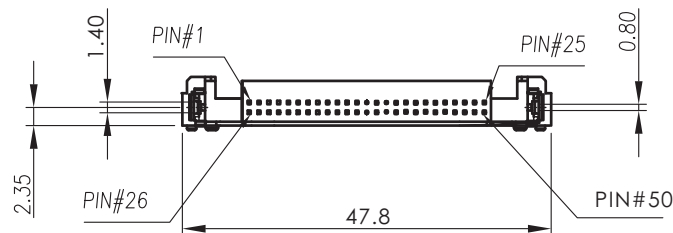
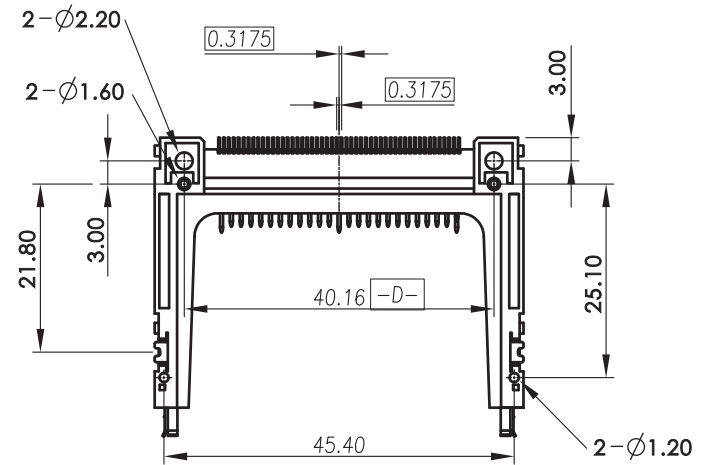
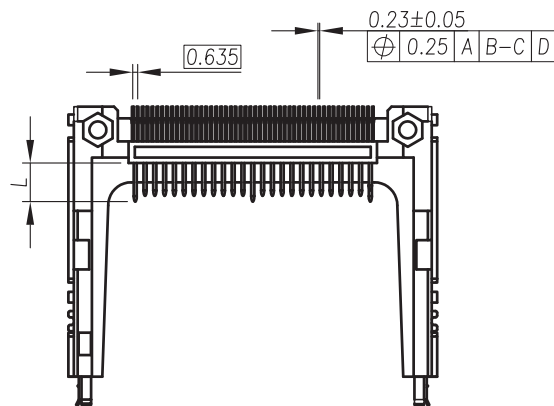
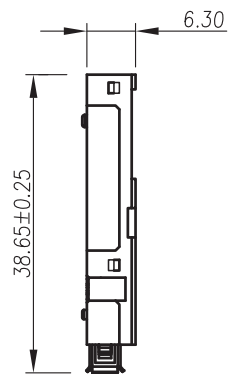
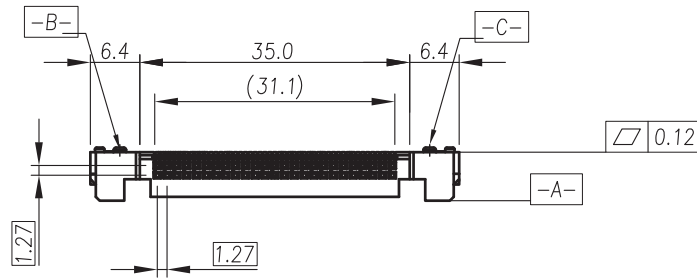

GENAL TOLERANCE .X ± 0.30 .XX ± 0.20 .XXX ± 0.10	DRAW DATE	2005/03/25 H. D. LI	PART NO CFP-503-XX2-WN-0D
	DESIGN	H. D. LI	TITLE CF Type2 50Pin SMT Normal Type
	CHECKED	Y. M. LU	
	APPROVED	J. F. KANG	
UNIT :mm			 宏揚精密有限公司 HOJAR PRECISION CO., LTD.

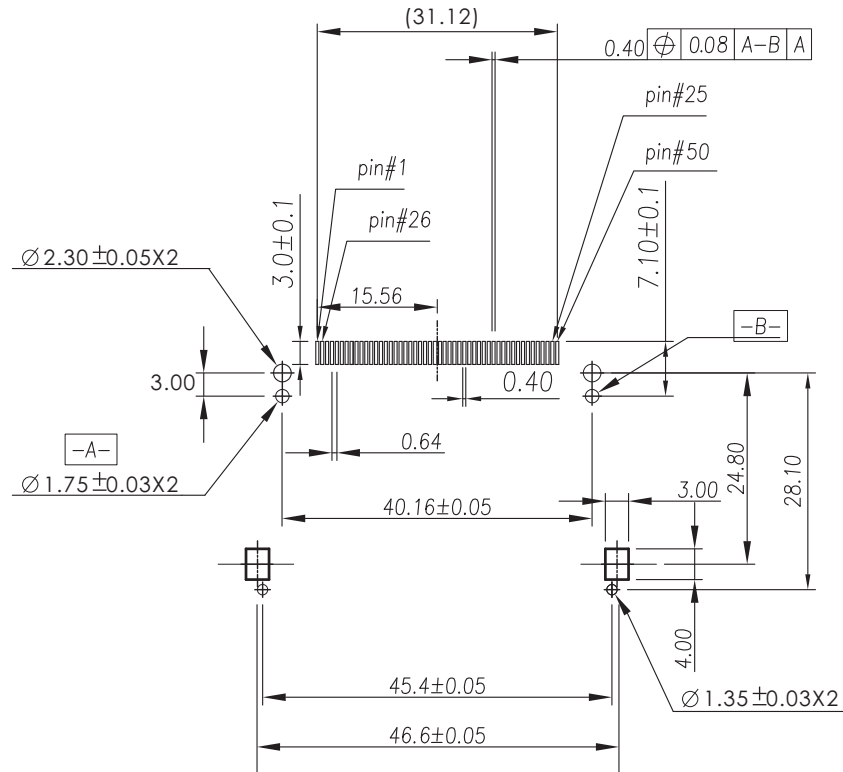

P.C.B Layout

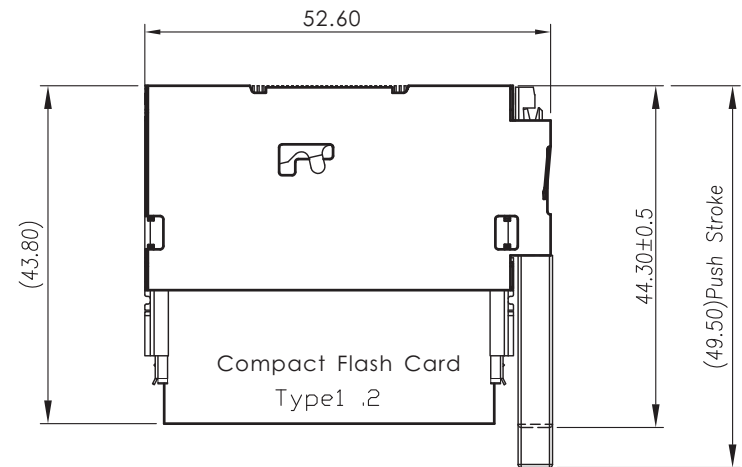

Header With Ejector

GENAL TOLERANCE .X ± 0.30 .XX ± 0.20 .XXX± 0.10	DRAW 2005/03/25 DATE H. D. LI	PART NO CFP-503-XX2-WN-0D
	DESIGN H. D. LI	TITLE CF Type2 50Pin SMT Normal Type
	CHECKED Y. M. LU	
	APPROVED J. F. KANG	
UNIT :mm		 宏揚精密有限公司 HOJAR PRECISION CO., LTD.