

# ORDER INFORMATION:

SDC1 - 032  $\frac{X}{a}$  -  $\frac{X}{b}$  -  $\frac{A/B/C}{c}$  -  $\frac{X}{d}$

- a. Center Pin Diameter:  
0:0.65  $\phi$
- b. Post selection:  
1: with post
- c. Length/Width/Height:  
A/B/C (A=11.0,B=5.0,C=5.0) (standard)
- d. Pack selection:  
R:Reel Pack

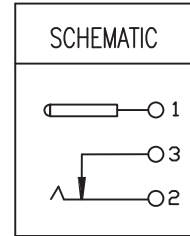
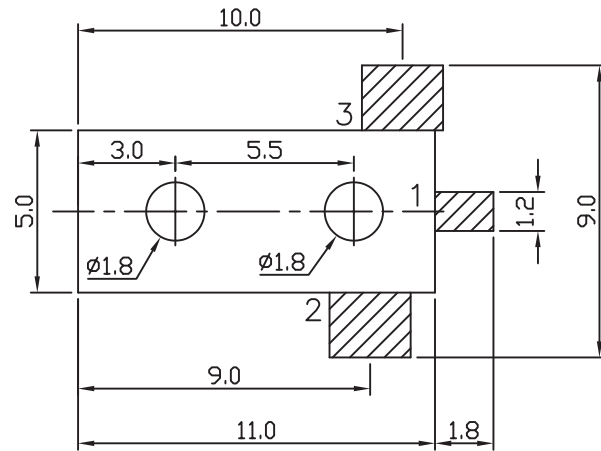

T:1.6 Dimensions of PC board holes

Tolerance :  $\pm 0.1$ (Printed-bottom view)

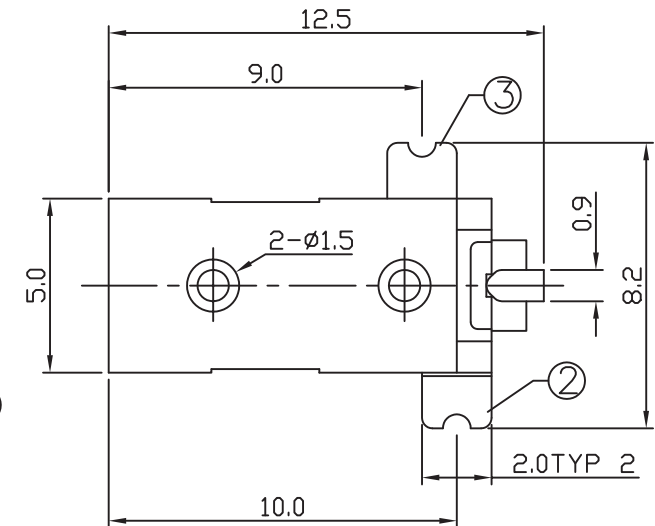
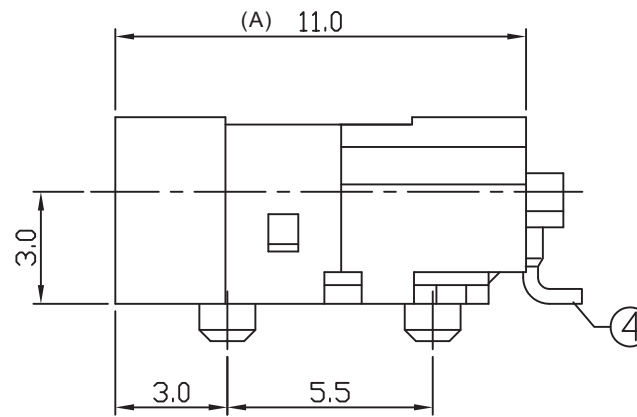
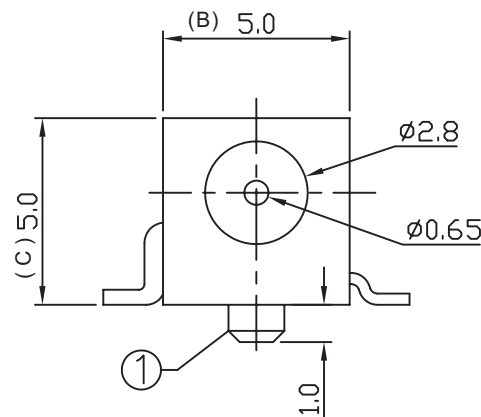

4	PIN	1	BRASS	MB:Cu Ni PLATED
3	SPRING	1	SUS 301	
2	CURVE PIECE	1	BRASS	MB:Cu Ag PLATED
1	HOUSING	1	PA9T	
LTR	PART NAME	QTY	MATERIAL	REMARK

GENAL TOLERANCE $\pm 0.2$	DRAW M. C. WANG	PART NO SDC1-032X-X-A/B/C-X
	DESIGN H. D. LI	TITLE DC POWER JACK (SMT)
	CHECKED Y. M. LU	
	APPROVED J. F. KANG	
UNIT :mm		 宏揚精密有限公司 HOJAR PRECISION CO., LTD.