

ORDER INFORMATION:

SDC038 - $\frac{XX}{a}$ B - $\frac{X}{b}$

a. Pin of numbers:

09

b. Pack selection:

D:Disk Pack

R:Reel Pack

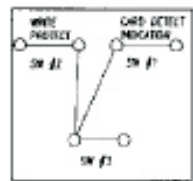
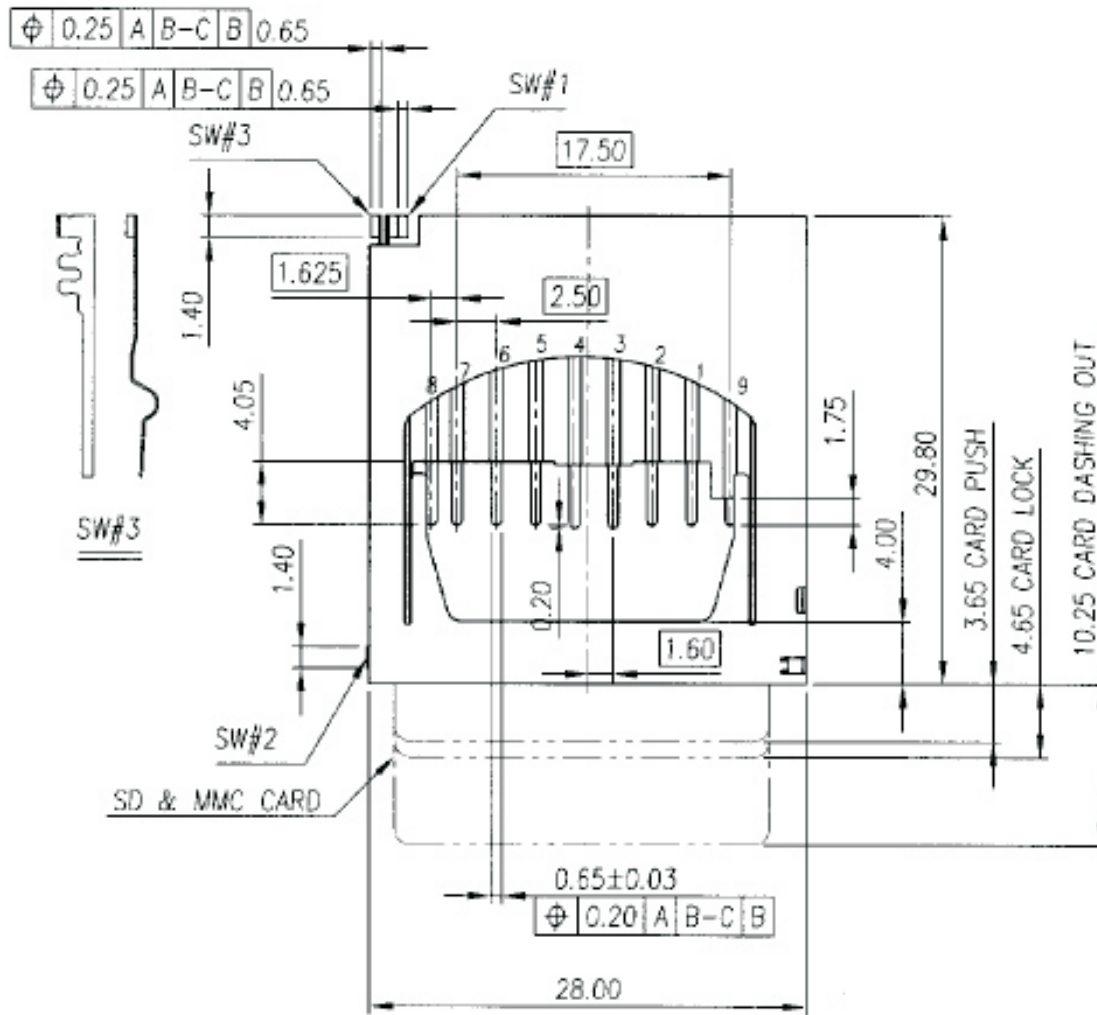

CARD INSERTED
WRITE PROTECT : UNLOCK

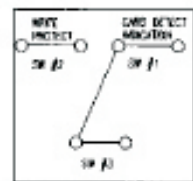

CARD INSERTED
WRITE PROTECT : LOCK



WITHOUT CARD

GENERAL TOLERANCE .X ± 0.30 .XX ± 0.20 .XXX ± 0.10	DRAW H. D. LI	PART NO SDC038-XXB-X
	DESIGN H. D. LI	TITLE SD MEMORY CARD PUSH-PUSH WITH CONNECTOR TYPE B (BIG SWITCH#3)
	CHECKED Y. M. LU	
	APPROVED J. F. KANG	
UNIT : mm		 宏揚精密有限公司 HOJANG PRECISION CO., LTD.

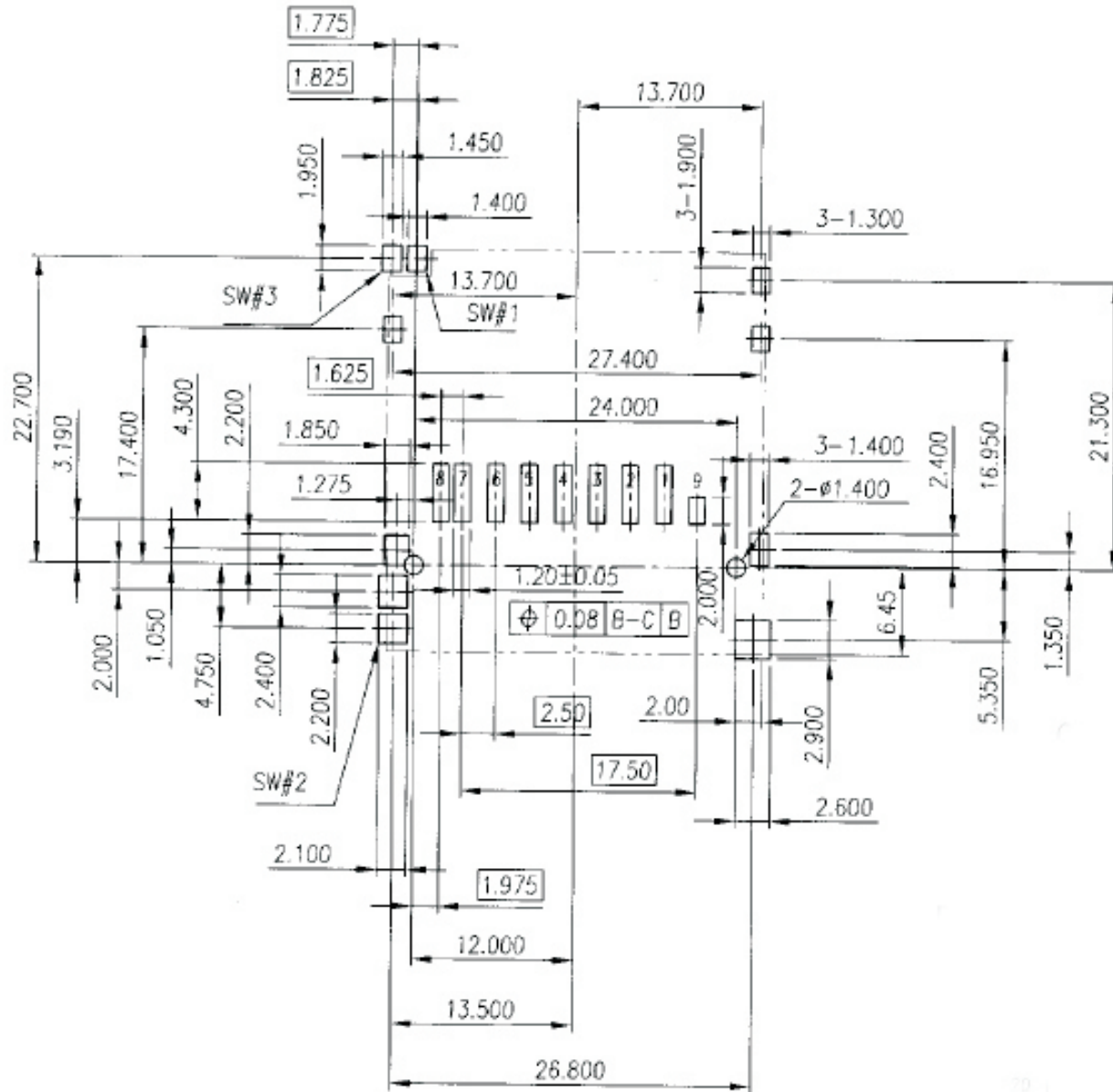

SD CARD PIN ASIGN	
PIN	NAME
1	CD/DAT3
2	CMD/D1
3	VSS1
4	VDD
5	CLK/SCLK
6	VSS2
7	DTA0
8	DTA1
9	DTA2

GENAL TOLERANCE .X ± 0.30 .XX ± 0.20 .XXX ± 0.10	DRAW	H. D. LI	PART NO	SDC038-XXB-X
	DESIGN	H. D. LI	TITLE	SD MEMORY CARD PUSH-PUSH WITH CONNECTOR TYPE B (BIG SWITCH#3)
	CHECKED	Y. M. LU		
	APPROVED	J. F. KANG		
UNIT :mm				 宏揚精密有限公司 HOJAR PRECISION CO., LTD.