

VERSION

A

## SPECIFICATIONS

Current Rating: 0.75Amp  
 Contact Resistance: 30m  $\Omega$  Max  
 Insulator Resistance: 1000M $\Omega$  Min  
 Withstanding Voltage : AC 500V  
 Operating Temperature:-40°to+ 105°  
 Contact Material: Phosphor Bronze  
 Insulator Material: Thermoplastic(UL 94V-0)  
 Standard : PA6T  
 Max.Processing Temp: 240C°-260C°for  
 30-60seconds(260C°for 10 seconds)

## ORDER INFORMATION:

SHFDJ7 - XX 6 - X X - XX - X  
 a b c d e f g

- a. Pin of numbers:  
06~100
- b. Pastic Thick  
6 : 3.00mm
- c. Plated selection:  
1 : Gold flash
- d. Post selection :  
0 : Without Post  
1 : Without Post+CAP
- e. Plastic Color :  
B : Black
- f. Plastic material selection:  
L : LCP
- e. Pack selection:  
T : Tube Pack  
R : Reel Pack

GENAL TOLERANCE	DRAW DATE	2004/08/02 H. D. LI	PART NO
X. $\pm$	DESIGN	H. D. LI	SHFDJ7-XX6-XX-XX-X
.X $\pm$ 0.38	CHECKED	Y. M. LU	TITLE
.XX $\pm$ 0.25	APPROVED	J. F. KANG	Pitch0.8 2xXX 母座 H=3.0mm SMD
.XXX $\pm$ 0.13	UNIT :mm		 宏揚精密有限公司 HOJAR PRECISION CO., LTD.

VERSION

A

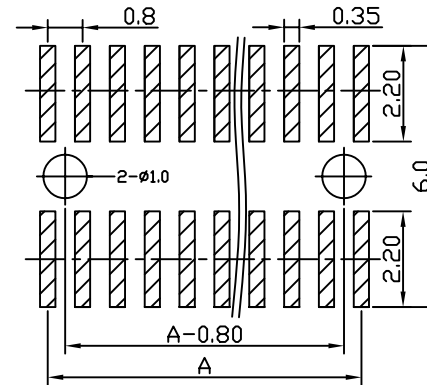
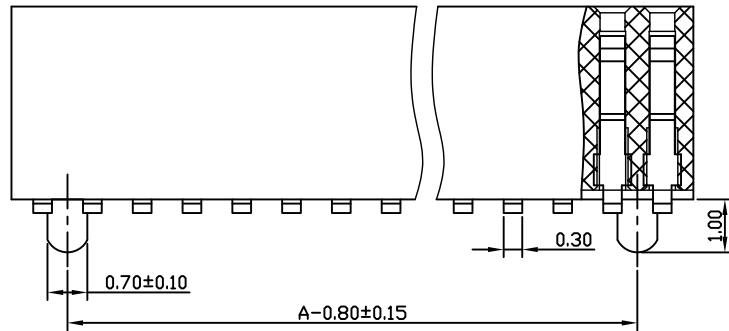
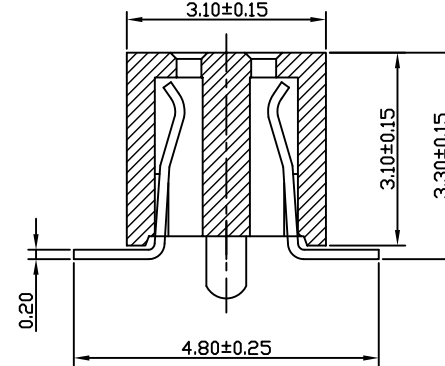
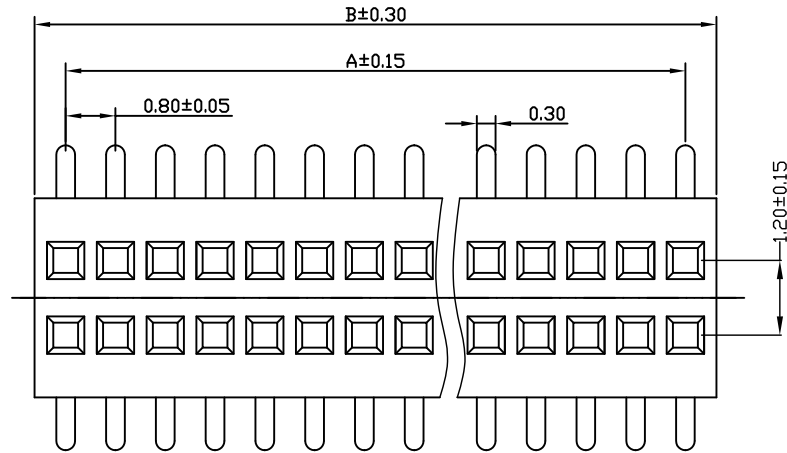

DIMENSIONS		
	A	B
2	0.80	1.90
3	1.60	2.70
4	2.40	3.50
5	3.20	4.30
6	4.00	5.10
7	4.80	5.90
8	5.60	6.70
9	6.40	7.50
10	7.20	8.30
11	8.00	9.10
12	8.80	9.90
13	9.60	10.70
14	10.40	11.50
15	11.20	12.30
16	12.00	13.10
17	12.80	13.90
18	13.60	14.70
19	14.40	15.50
20	15.20	16.30
21	16.00	17.10
22	16.80	17.90
23	17.60	18.70
24	18.40	19.50
25	19.20	20.30
26	20.00	21.10
27	20.80	21.90
28	21.60	22.70
29	22.40	23.50
30	23.20	24.30
31	24.00	25.10
32	24.80	25.90
33	25.60	26.70
34	26.40	27.50
35	27.20	28.30
36	28.00	29.10
37	28.80	29.90
38	29.60	30.70
39	30.40	31.50
40	31.20	32.30
41	32.00	33.10
42	32.80	33.90
43	33.60	34.70
44	34.40	35.50
45	35.20	36.30
46	36.00	37.10
47	36.80	37.90
48	37.60	38.70
49	38.40	39.50
50	39.20	40.30

RECOMMEND P. C. BOARD LAYOUT

PCB TOLERANCE:  $\pm 0.05$  (TOP VIEW)

GENERAL TOLERANCE X. $\pm$ .X $\pm 0.38$ .XX $\pm 0.25$ .XXX $\pm 0.13$	DRAW DATE 2004/08/02 H. D. LI	PART NO SHFDJ7-XX6-XX-XX-X
	DESIGN H. D. LI	TITLE Pitch0.8 2xXX 母座 H=3.0mm SMD
	CHECKED Y. M. LU	
	APPROVED J. F. KANG	
UNIT :mm		 宏揚精密有限公司 HOJAR PRECISION CO., LTD.