

SPECIFICATIONS

Current Rating : 1 Amps

Insulator resistance : 5000 Megohms

Dielectric withstanding : AC 500V

Operating Temperature : -40° — +105°C

MATERIAL :

Housing : High Temperature Thermoplastic

Terminal : Brass 65/35(2680)

ORDER INFORMATION:SHBH24 - $\frac{XX}{a}$ $\frac{X}{b}$ - $\frac{X}{c}$ $\frac{X}{d}$ - B - $\frac{X}{f}$ $\frac{X}{g}$ - $\frac{X}{h}$

a. Pin of numbers:

10 ~ 100

b. Height Type:

1 : H=3.6mm

2 : H=4.6mm

c. 0 : Tin Plated

1 : Gold Flash

2 : Gold 5u"

3 : Gold 15u"

4 : Gold 30u"

d. Post

0:None Post

1:With Post

2:None Post + Cap

3:With Post + Cap

e. Solder Pin Length:

if you desire on other length, by marking put desired length the B.

f. Plastic Color :

W : white B : black

g. Plastic Material

L:L.C.P N:Nylon 6T

N9:Nylon 9T(E)

h. Pack Selection :

D : Disk Pack (standard)

R : Reel Pack

VERSION & EC DESCRIPTION			
DATE	VERSION	PAGE	DESCRIPTION
2003/09/01	A	14-15	Add SHBH24-XX2 Series Plan
2004/08/02	B	14-15	Revise SHBH24-XX2 Series Plan
2004/08/12	B	14	Add Material : N1
2004/12/16	B	14-15	Revise Order information B
2004/12/24	B	14	Revise Material : N1 => N9
2005/02/22	B	14	Add Pack : Disk & Reel

GENERAL TOLERANCE	DRAW DATE	2003/09/01 H. D. LI	PART NO
X. ± 0.50	DESIGN	H. D. LI	SHBH24 - XX 2 - X X - X - BX-X
.X ± 0.38	CHECKED	Y. M. LU	TITLE
.XX ± 0.25	APPROVED	J. F. KANG	Pitch:1.27x1.27mm Box Header SMD 2:XX W/Post
.XXX ± 0.15	UNIT :mm		 宏揚精密有限公司 HOJAR PRECISION CO. : LTD.

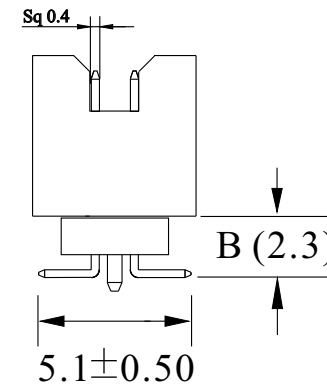
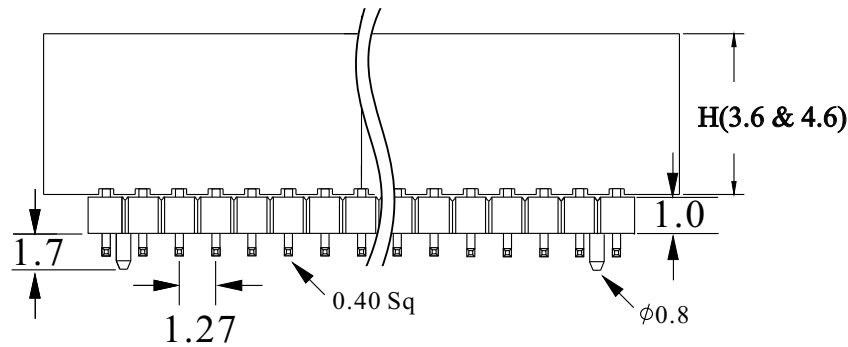
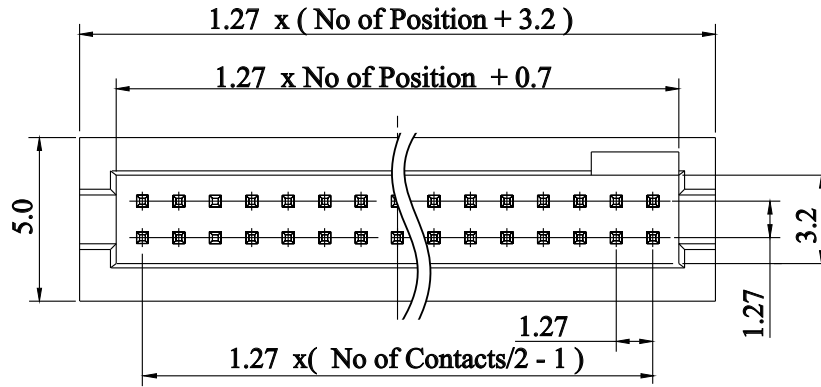

Recommended P.C.Board Hole Layout :

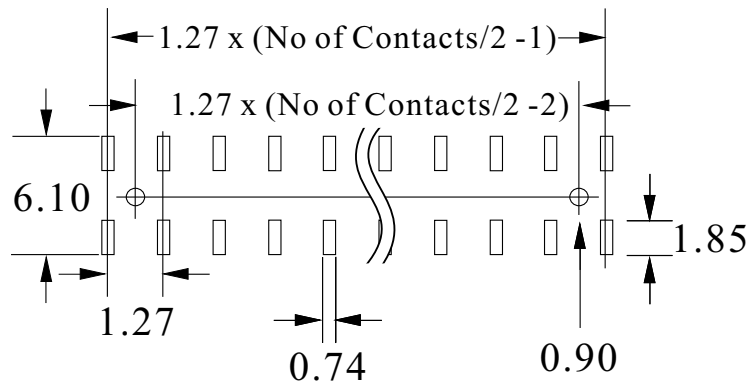

GENERAL TOLERANCE X. ± 0.50 .XX ± 0.38 .XXX ± 0.25 .XXX ± 0.15	DRAW DATE 2003/09/01 H. D. LI	PART NO SHBH24 - XX 2 - X X - X - BX-X
	DESIGN H. D. LI	TITLE Pitch:1.27x1.27mm Box Header SMD 2xXX W/Post
	CHECKED Y. M. LU	
	APPROVED J. F. KANG	
UNIT :mm		 宏揚精密有限公司 HOJAR PRECISION CO. : LTD.