

VERSION

A

ORDER INFORMATION:

SFPCRB05 - $\frac{XX}{a}$ 3 - L - $\frac{X}{b}$

NOTES:

1. MATERIAL:

HOUSING: HIGHT-TEMP PLASTIC,UL 94-V0,COLOR:NATURE;
COVER: HIGHT-TEMP PLASTIC,UL 94-V0,COLOR:BLACK;
CONTACT: COPPER ALLOY;
LEG: COPPER ALLOY;

2. PLATING:

CONTACT: GOLD OR TIN PLATED ON NICKEL OVERALL.
LEG: TIN PLATED ON NICKEL OVERALL.

3. RATING:

CURRENT RATING: 0.4A AC/DC
VOLTAGE RATING: 50V AC/DC
TEMPERATURE RANGE: -55°C~+85°C;

a. NO . Of Contacts
04~40

b. Pack selection:
T : Tube Pack
R : Reel Pack

GENAL TOLERANCE X. ± .X ± .XX ± .XXX ±	DRAW DATE 2004/08/11 H. D. LI	PART NO SFPCRB05-XX3-L-X
	DESIGN H. D. LI	TITLE FPC Connector0.5mm Press c Type H:1.0
	CHECKED Y. M. LU	
UNIT :mm	APPROVED J. F. KANG	 宏揚精密有限公司 HOJAR PRECISION CO., LTD.

VERSION

A

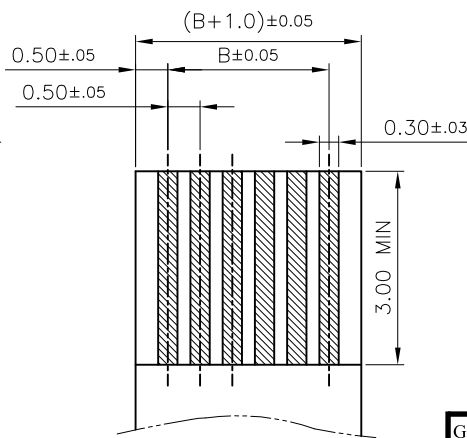
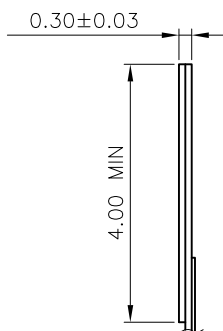
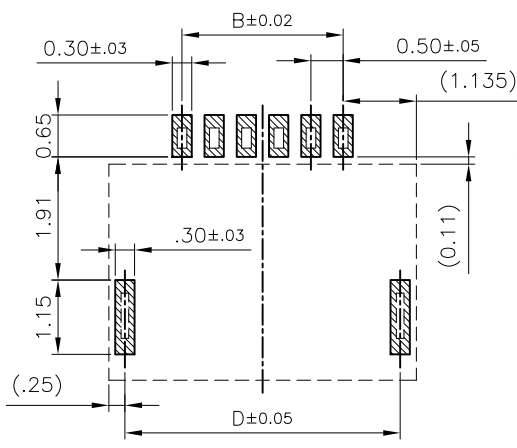
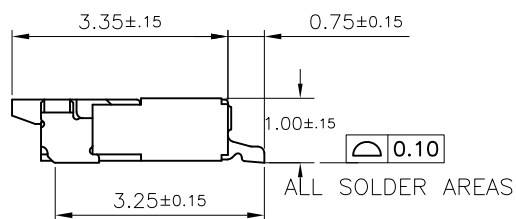
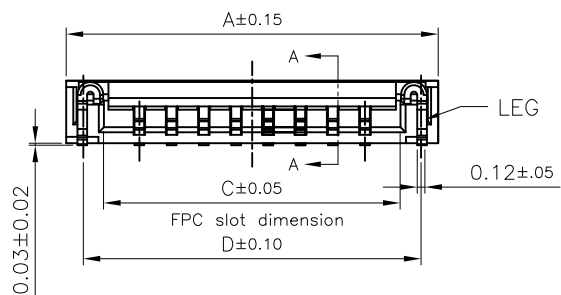
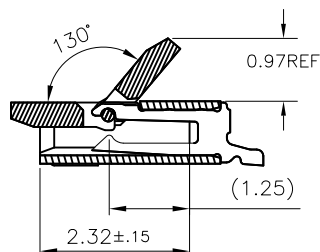
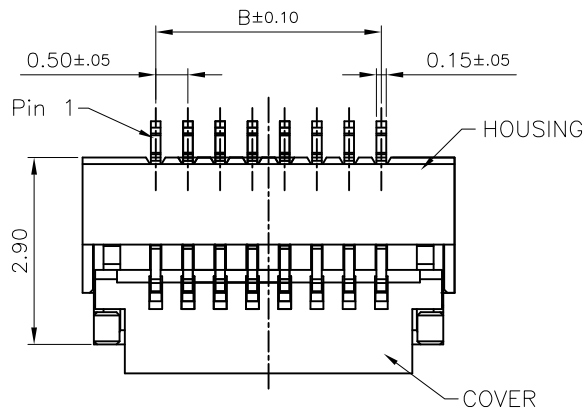

RECOMMEND PCB LAYOUT
TOLERANCE: ±0.05

Applicable FPC

PIN NO	DIM. A	DIM. B	DIM. C	DIM. D
04	3.77	1.50	2.60	3.27
05	4.27	2.00	3.10	3.77
06	4.77	2.50	3.60	4.27
07	5.27	3.00	4.10	4.77
08	5.77	3.50	4.60	5.27
09	6.27	4.00	5.10	5.77
10	6.77	4.50	5.60	6.27
11	7.27	5.00	6.10	6.77
12	7.77	5.50	6.60	7.27
13	8.27	6.00	7.10	7.77
14	8.77	6.50	7.60	8.27
15	9.27	7.00	8.10	8.77
16	9.77	7.50	8.60	9.27
17	10.27	8.00	9.10	9.77
18	10.77	8.50	9.60	10.27
19	11.27	9.00	10.10	10.77
20	11.77	9.50	10.60	11.27
21	12.27	10.00	11.10	11.77
22	12.77	10.50	11.60	12.27
23	13.27	11.50	12.10	12.77
24	13.77	11.50	12.60	13.27
25	14.27	12.00	13.10	13.77
26	14.77	12.50	13.60	14.27
27	15.27	13.00	14.10	14.77
28	15.77	13.50	14.60	15.27
29	16.27	14.00	15.10	15.77
30	16.77	14.50	15.60	16.27
31	17.27	15.00	16.10	16.77
32	17.77	15.50	16.60	17.27
33	18.27	16.00	17.10	17.77
34	18.77	16.50	17.60	18.27
35	19.27	17.00	18.10	18.77
36	19.77	17.50	18.60	19.27
37	20.27	18.00	19.10	19.77
38	20.77	18.50	19.60	20.27
39	21.27	19.00	20.10	20.77
40	21.77	19.50	20.60	21.27

GENAL TOLERANCE X. ± .X ± .XX ± .XXX ±	DRAW DATE	2004/08/11 H. D. LI	PART NO SFPCRB05-XX3-L-X
	DESIGN	H. D. LI	
	CHECKED	Y. M. LU	TITLE FPC Connector 0.5mm Press c Type H:1.0
	APPROVED	J. F. KANG	 宏揚精密有限公司 HOJAR PRECISION CO., LTD.
UNIT :mm			