

MATERIAL

INSULATOR: GLASS-REINFORCED THERMOPLASTIC.

CONTACT: COPPER ALLOY.

PLATING: ALL TIN,LEAD FREE.

ELECTRICAL

CURRENT RATING : 0.5 Amp

DIELECTRIC WITHSTANDING VOLTAGE : 500 VAC MIN.

INSULATION RESISTANCE: 1000 MEGAOHMS MIN.

CONTACT RESISTANCE : 30 MILLIOHMS MAX.

ENVIRONMENTAL

TEMPERATURE RANGE : -55°C TO +85°C

ORDER INFORMATION:FPC125 - $\frac{XX}{a}$ 3 - D H - S - $\frac{X}{b}$

a. Pin of numbers:

04 ~ 30

b. Pack :

T : Tube

VERSION & EC DESCRIPTION

DATE	VERSION	PAGE	DESCRIPTION
2004/12/30	A	14-15	Add FPC125-XX3-DH-S-T Plan
2006/05/25			修改外觀尺寸

GENERAL TOLERANCE	VER DRE. 2006/05/25	PART NO
X. ±0.40	H. D. LI	FPC125 - XX3 - DH - S - T
.X ±0.30	DESIGN	TITLE
.XX ±0.20	H. D. LI	1.25mm FPC DIP SIDE ENTRY DUAL
.XXX ±0.10	CHECKED	CONTACT NON ZIF SPECIAL PCB LAYOUT
	Y. M. LU	
	APPROVED	
UNIT :mm	J. F. KANG	 宏揚精密有限公司 HOJAR PRECISION CO., LTD.

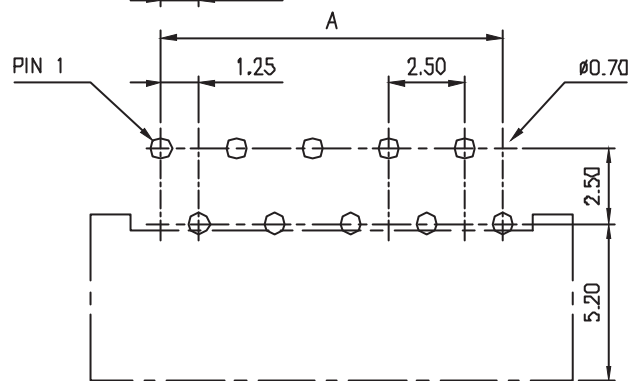
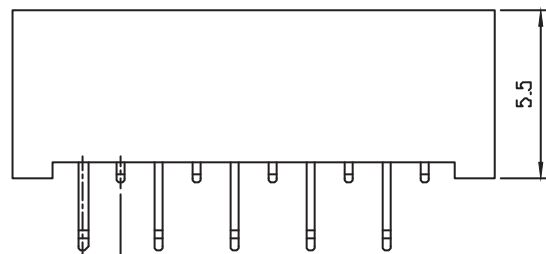
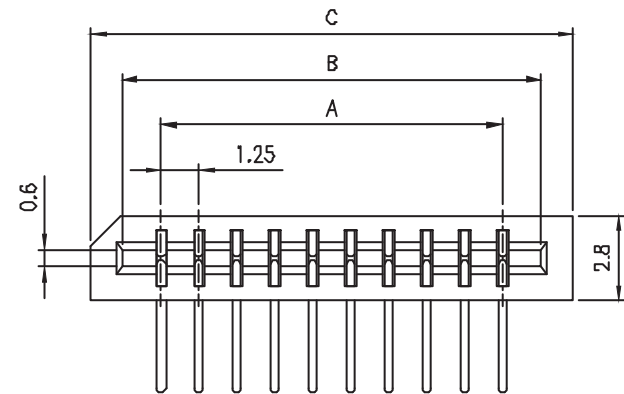

RECOMMENDED PCB LAYOUT

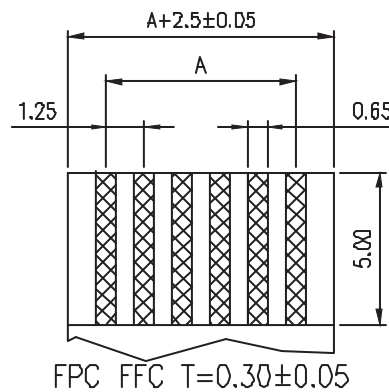
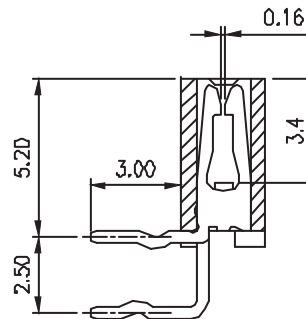

DIMENSION TABLE

Circuits	Dimension			Circuits	Dimension		
	A	B	C		A	B	C
4	3.75	6.30	8.40	21	25.00	27.55	29.65
5	5.00	7.55	9.65	22	26.25	28.80	30.90
6	6.25	8.80	10.90	23	27.50	30.05	32.15
7	7.50	10.05	12.15	24	28.75	31.30	33.40
8	8.75	11.30	13.40	25	30.00	32.55	34.65
9	10.00	12.55	14.65	26	31.25	33.80	35.90
10	11.25	13.80	15.90	27	32.50	35.05	37.15
11	12.50	15.05	17.15	28	33.75	36.30	38.40
12	13.75	16.30	18.40	29	35.00	37.55	39.65
13	15.00	17.55	19.65	30	36.25	38.80	40.90
14	16.25	18.80	20.90				
15	17.50	20.05	22.15				
16	18.75	21.30	23.40				
17	20.00	22.55	24.65				
18	21.25	23.80	25.90				
19	22.50	25.05	27.15				
20	23.75	26.30	28.40				

GENAL TOLERANCE X. ±0.40 .X ±0.30 .XX ±0.20 .XXX ±0.10	VER DRE. 2006/05/25 H. D. LI	PART NO FPC125-XX3-DH-S-T
	DESIGN H. D. LI	TITLE 1.25mm FPC DIP SIDE ENTRY DUAL CONTACT NON ZIF SPECIAL PCB LAYOUT
	CHECKED Y. M. LU	
UNIT :mm	APPROVED J. F. KANG	 宏揚精密有限公司 HOJAR PRECISION CO., LTD.