

MATERIAL

INSULATOR : GLASS - REINFORCED THERMOPLASTIC.
 CONTACTS : PHOSPHOR BRONZE.
 PLATING : ALL TIN,LEAD FREE.

SPECIFICATIONS

VOLTAGE RATING : 250 VAC RMS.
 CURRENT RATING : 1 AMP.
 DIELECTRIC WITHSTANDING VOLTAGE :
 1000 VAC RMS 60 Hz FOR 1 MINUTE.
 INSULATION RESISTANCE :
 5000 MEGOHMS MIN AT 500 VDC.
 CONTACT RESISTANCE : 25 MILLIOHMS MAX.
 DURABILITY : 20 CYCLES.

ENVIRONMENTAL

TEMPERATURE RANGE : -55°C TO + 85°C

ORDER INFORMATION:

FPCR125 - $\frac{XX}{a} 1 - \frac{L}{b} \frac{X}{c} - \frac{X}{d}$

- a. Pin of numbers:
04 ~ 30
- b.
L : 下接觸(standard)
- c.
X : 錯腳位(standard)
- d. Pack :
T : Tube

VERSION & EC DESCRIPTION

DATE	VERSION	PAGE	DESCRIPTION
2004/04/21	A	8-9	Add FPCR125-XX1-LX-X Plan
2006/05/25			修改尺寸

GENERAL TOLERANCE X. ± 0.40 .X ± 0.30 .XX ± 0.20 .XXX ± 0.10	VER DRE. 2006/05/25 H. D. LI	PART NO FPCR125 - XX 1 - LX - X
	DESIGN H. D. LI	TITLE 1.25mm FPC DIP Lower Contact X Type Non ZIF
	CHECKED Y. M. LU	
UNIT :mm	APPROVED J. F. KANG	 宏揚精密有限公司 HOJAR PRECISION CO., LTD.

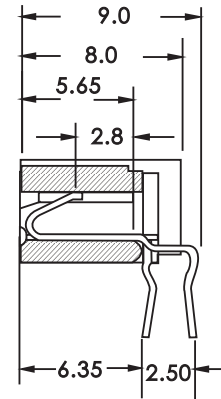
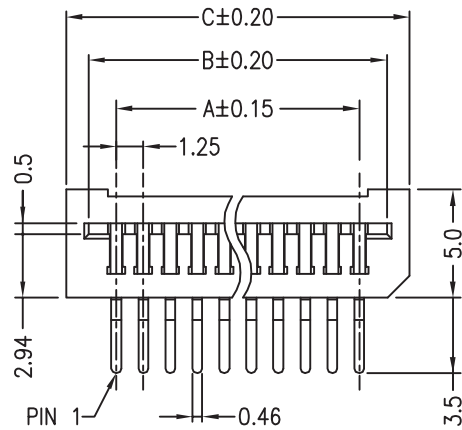
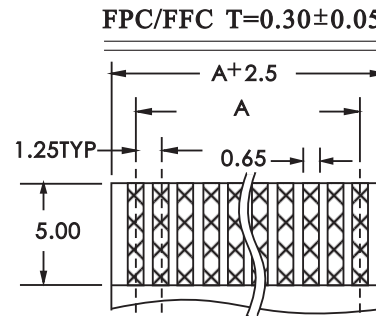
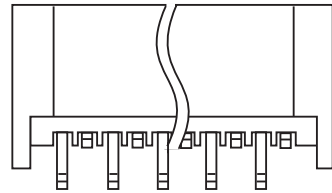

Standard PCB Layout

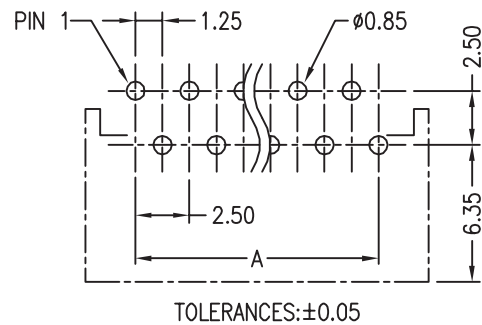

Contacts	A	B	C	Contacts	A	B	C
4	3.75	6.30	8.40	21	25.00	27.55	29.65
5	5.00	7.55	9.65	22	26.25	28.80	30.90
6	6.25	8.80	10.90	23	27.50	30.05	32.15
7	7.50	10.05	12.15	24	28.75	31.30	33.40
8	8.75	11.30	13.40	25	30.00	32.55	34.65
9	10.00	12.55	14.65	26	31.25	33.80	35.90
10	11.25	13.80	15.90	27	32.50	35.05	37.15
11	12.50	15.05	17.15	28	33.75	36.30	38.40
12	13.75	16.30	18.40	29	35.00	37.55	39.65
13	15.00	17.55	19.65	30	36.25	38.80	40.90
14	16.25	18.80	20.90				
15	17.50	20.05	22.15				
16	18.75	21.30	23.40				
17	20.00	22.55	24.65				
18	21.25	23.80	25.90				
19	22.50	25.05	27.15				
20	23.75	26.60	28.40				

GENAL TOLERANCE X. ± 0.40 .X ± 0.30 .XX ± 0.20 .XXX ± 0.10	VER DRE. 2006/05/25 H. D. LI	PART NO FPCR125 - XX 1 - LX - X
	DESIGN H. D. LI	TITLE 1.25mm FPC DIP Lower Contact X Type Non ZIF
	CHECKED Y. M. LU	
	APPROVED J. F. KANG	
UNIT :mm		宏揚精密有限公司 HOJAR PRECISION CO., LTD.