

TOLERANCES: ±0.05
RECOMMENDED PCB LAYOUT

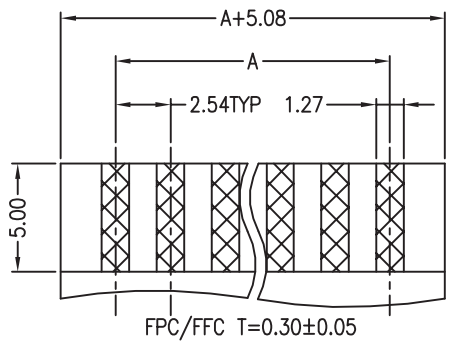

ORDER INFORMATION:

DHFPC254030 - $\frac{XX1}{a}$ - $\frac{V}{b}$ - $\frac{XP - X}{c}$

- a. Pin of numbers:
02 ~ 27
- b. color:
B:Black
W:White
- c. Pack :
T : Tube

MATERIAL
INSULATOR: GLASS-REINFORCED THERMOPLASTIC.
CONTACT: PHOSPHOR BRONZE.
PLATING: ALL TIN, LEAD FREE.

SPECIFICATION
VOLTAGE RATING: 250 VAC RMS.
CURRENT RATING: 1 AMP.
DIELECTRIC WITHSTANDING VOLTAGE: 1000 VAC RMS 60 Hz.
FOR 1 MINUTE.
INSULATION RESISTANCE: 5000 MEGOHMS MIN AT 500 VDC.
CONTACT RESISTANCE: 25 MILLIOHMS MAX.
DURABILITY: 20 CYCLES.

ENVIRONMENTAL
TEMPERATURE RANGE: -55°C TO +85°C.

Circuit	Dimension			Circuit	Dimension		
	A	B	C		A	B	C
2	2.54	8.43	10.54	15	35.56	41.45	43.56
3	5.08	10.97	13.08	16	38.10	43.99	46.10
4	7.62	13.51	15.62	17	40.64	46.53	48.64
5	10.16	16.05	18.16	18	43.18	49.07	51.18
6	12.70	18.59	20.70	19	45.72	51.60	53.72
7	15.24	21.13	23.24	20	48.26	54.15	56.26
8	17.78	23.67	25.78	21	50.80	56.69	58.80
9	20.32	26.21	28.32	22	53.34	59.23	61.34
10	22.86	28.75	30.86	23	55.88	61.77	63.88
11	25.40	31.29	33.40	24	58.42	64.31	66.42
12	27.94	33.83	35.94	25	60.96	66.85	68.96
13	30.48	36.37	38.48	26	63.50	69.39	71.50
14	33.02	38.91	41.02	27	66.04	71.93	74.04

GENERAL TOLERANCE X. ± 0.40 .X ± 0.30 .XX ± 0.20 .XXX ± 0.10	VER DRE. 2004/04/21 H. D. LI	PART NO DHFPC254030 - XX1 - V - XP - X
	DESIGN H. D. LI	TITLE FPC/FFC 2.54 PITCH NON ZIF TOP ENTRY DUAL CONTACT
	CHECKED Y. M. LU	
UNIT :mm	APPROVED J. F. KANG	宏揚精密有限公司 HOJAR PRECISION CO. : LTD.