

ORDER INFORMATION:

USBA1 - 041 - $\frac{X}{a}$ - S - $\frac{X}{b} \frac{X}{c}$ - $\frac{X}{d}$

- a. Plated selection :
 - 1 : Gold Flash
 - 2 : Gold 30u"
- b. Plastic Color :
 - B : Black
 - W : White
- c. Plastic material :
 - P : P.B.T (standard)
 - N : Nylon 9T
- d. Pack selection:
 - D : Disk Pack

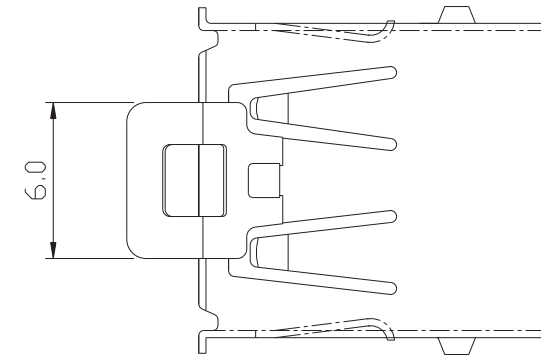
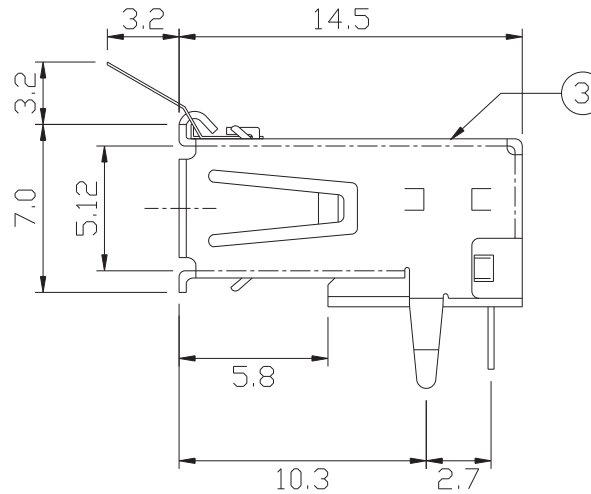
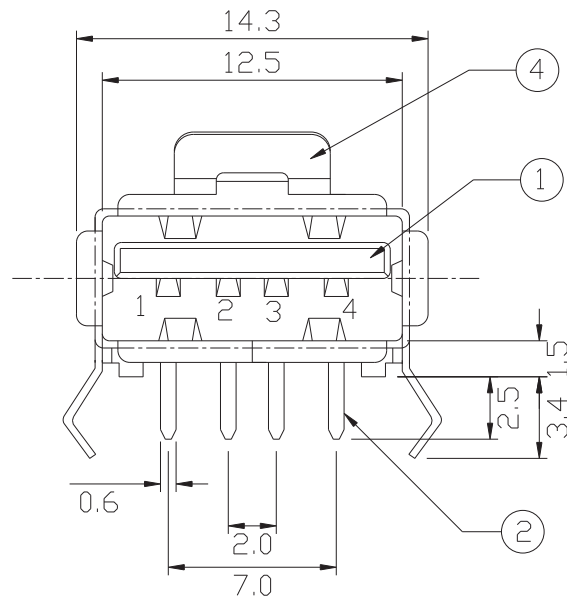

NO.	NAME	MATERIAL	FINISH	REMARK	QTY
1	HOUSING	PBT G.F.	WHITE		1
2	PIN TERM.	PHOS. BRONZE T:0.25	GOLD/TIN PLATED	Gold:1~3u"; NI:40~60u"; TIN:120u" (100% pure Tin of lead free plating)	4
3	SHELL	BRASS T:0.3	NICKEL PLATED	NI:80~120u"	1
4	SPRING SHIELD	STAINLESS T:0.1			

GENAL TOLERANCE ± 0.30	DATE H. D. LI	PART NO USBA1-041-X-S-XX-X
	DESIGN H. D. LI	TITLE USB TYPE A WITH SPRING FLAT 90度 DIP
	CHECKED Y. M. LU	
UNIT :mm	APPROVED J. F. KANG	 宏揚精密有限公司 HOJAR PRECISION CO., LTD.