

PCB LAYOUT  
(BOTTOM VIEW)

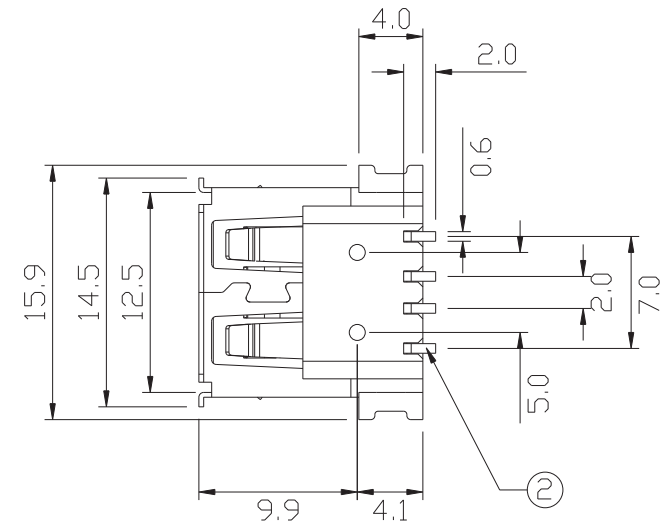
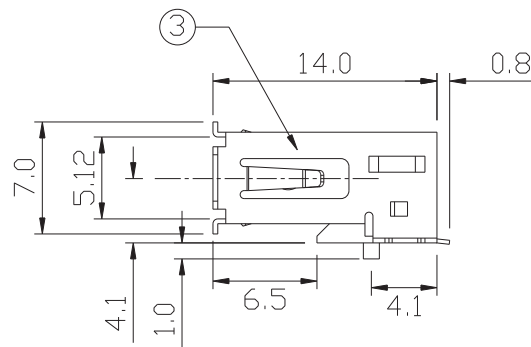
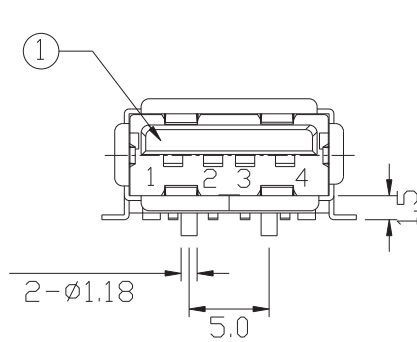
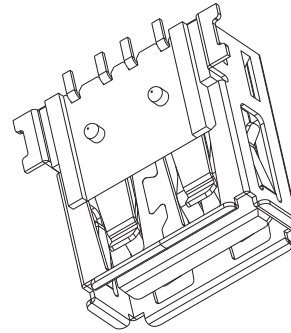

## ORDER INFORMATION:

SUSBA1 - 042 -  $\frac{X}{a} - \frac{X}{b} \frac{X}{c} - \frac{X}{d}$

- a. Plated selection :  
 1 : Gold Flash  
 2 : Gold 30u"  
 b. Plastic Color :  
 B : Black  
 W : White  
 c. Plastic material :  
 P : P.B.T  
 N : Nylon 9T (standard)  
 d. Pack selection:  
 D : Disk Pack

NO.	NAME	MATERIAL	FINISH	REMARK	QTY
1	HOUSING	NYLON PA9T G.F.	BLACK		1
2	PIN TERM.	PHOS. BRONZE T:0.25	GOLD/TIN PLATED	Gold:1~3u; NI:40~60u*; TIN:120u* (100% pure Tin of lead free plating)	4
3	SHELL	BRASS T:0.3	NICKEL PLATED	NI:80~120u*	1

GENAL TOLERANCE	DATE	PART NO
	± 0.30	H. D. LI
	DESIGN	TITLE
	H. D. LI	USB TYPE A FLAT 90度 SMT
	CHECKED	
	Y. M. LU	
	APPROVED	
UNIT :mm	J. F. KANG	
		宏揚精密有限公司 HOJAR PRECISION CO., LTD.