

ORDER INFORMATION:

SUSBB1 - 04V -  $\frac{X}{a}$  -  $\frac{X}{b}$   $\frac{X}{c}$  -  $\frac{X}{d}$

- a. Plated selection :
  - 1 : Gold Flash
  - 2 : Gold 30u"
- b. Plastic Color :
  - B : Black
  - W : White
- c. Plastic material :
  - P : P.B.T
  - N : Nylon 9T (standard)
- d. Pack selection:
  - D : Disk Pack

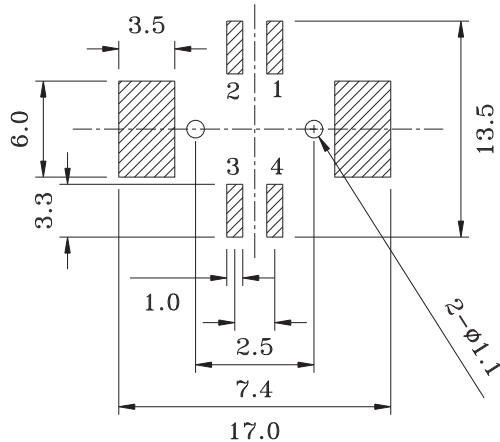

(COMPONENT SIDE)  
PCB LAYOUT

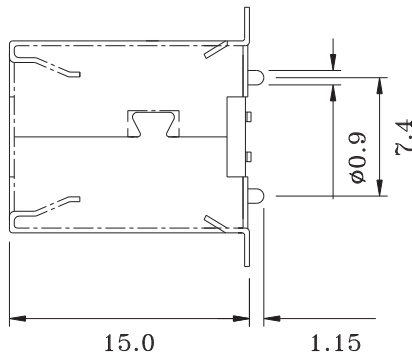
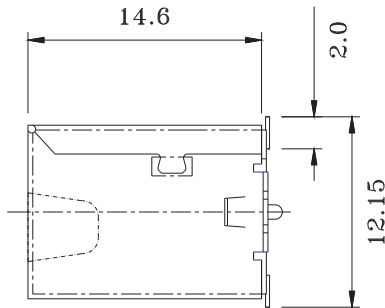
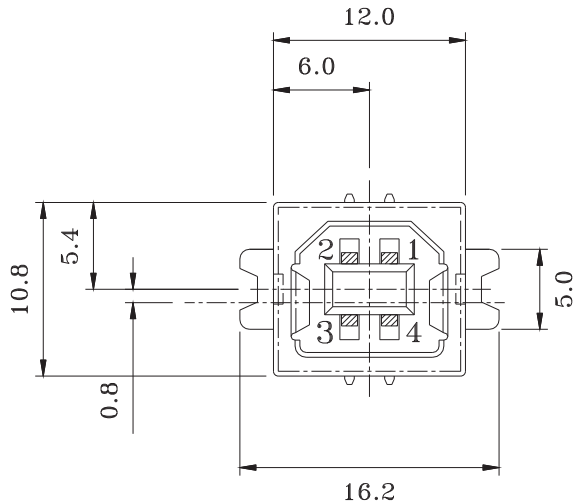
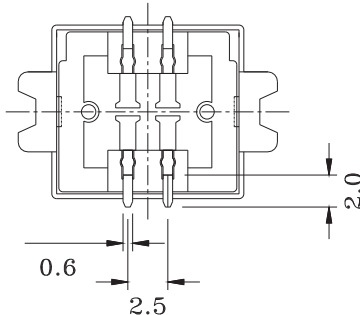

NO.	NAME	MATERIAL	FINISH	REMARK	Q'TY
1	HOUSING	NYLON PA9T G.F	BLACK		1
2	PIN TERM.	PHOS. BRONZE T:0.25	GOLD/TIN PLATED	Gold:1~3 μm; NI:40~60 μm; TIN:120 μm (100% pure Tin of lead free plating)	4
3	SHELL	BRASS T:0.3	NICKEL PLATED	NI:80~120u"	1

GENAL TOLERANCE ± 0.30	DATE H. D. LI	PART NO SUSBB1-04V-X-XX-X
	DESIGN H. D. LI	TITLE USB TYPE B 180度 SMT
	CHECKED Y. M. LU	
UNIT :mm	APPROVED J. F. KANG	 宏揚精密有限公司 HOJAR PRECISION CO., LTD.