

**ORDER INFORMATION:**

DUSBA1 - 081 -  $\frac{X}{a}$  -  $\frac{XX}{b}$  -  $\frac{X}{c}$  -  $\frac{X}{d}$

- a. Plated selection :
  - 1 : Gold Flash
  - 2 : Gold 30u"
- b. Plastic Color :
  - B : Black
  - W : White
- c. Plastic material :
  - P : P.B.T
  - N : Nylon 9T (standard)
- d. Pack selection:

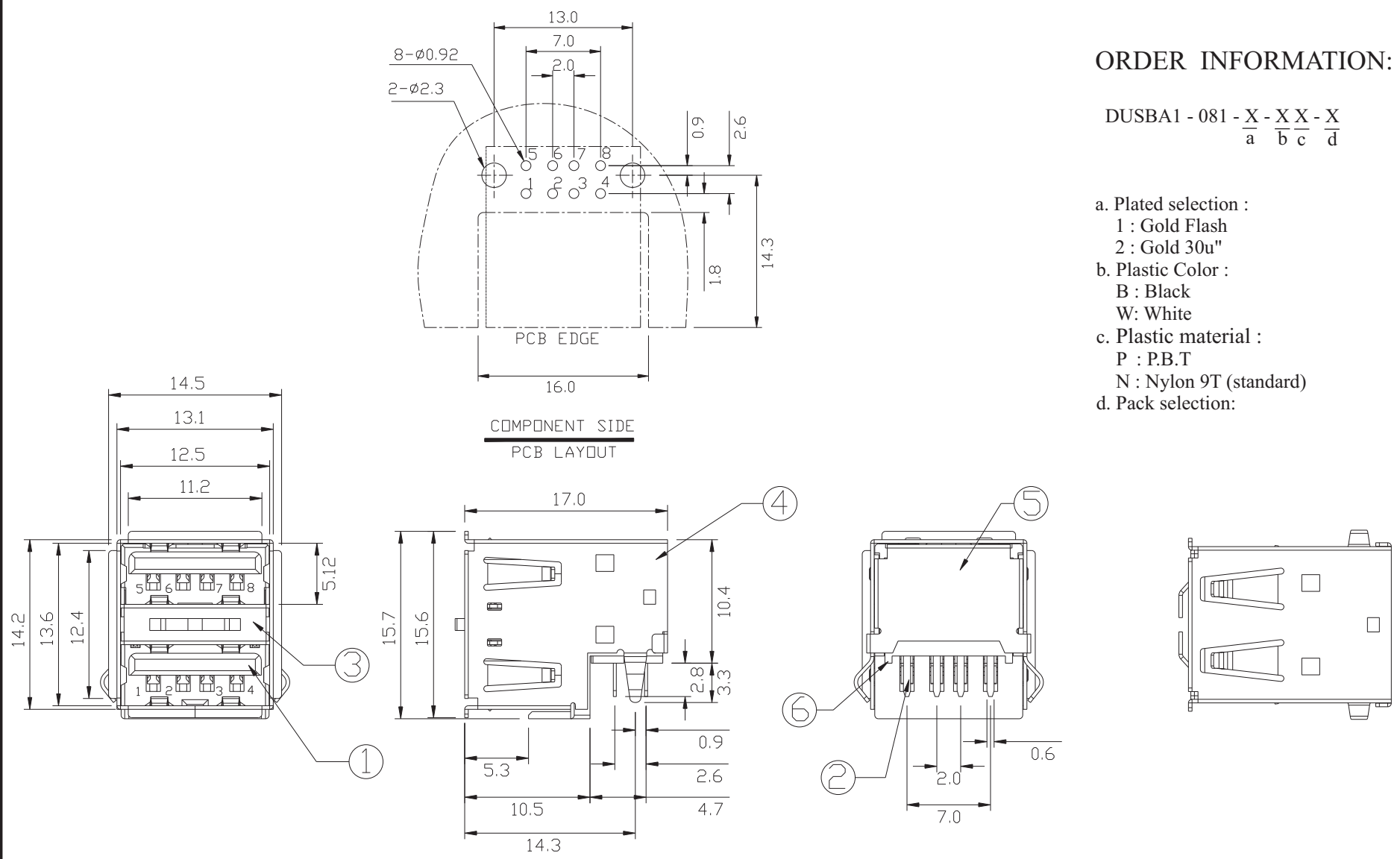

NO.	NAME	MATERIAL	FINISH	Q'TY	REMARK
1	HOUSING	NYLON PA9T G.F.	BLACK	1	
2	PIN TERM.	PHOS. BRONZE	GOLD-TIN PLATED	8	Gold:1~3u"; NI:40~60u"; TIN:120u" (100% pure Tin of lead free plating)
3	SHELL	BRASS,0.3mm	NICKEL PLATED	1	NI:80~120u"
4	SHELL	BRASS,0.3mm	NICKEL PLATED	1	NI:80~120u"
5	SHELL	SPCC,0.3mm	NICKEL PLATED	1	NI:80~120u"
6	BOTTOM COVER	NYLON PA9T G.F.	BLACK	1	

GENAL TOLERANCE ± 0.30	DATE H. D. LI	PART NO DUSBA1-081-X-XX-X
	DESIGN H. D. LI	TITLE DUAL USB A TYPE
	CHECKED Y. M. LU	
UNIT :mm	APPROVED J. F. KANG	

