

ORDER INFORMATION:

SMUSBA1- 041 - $\frac{X}{a}$ - $\frac{X}{b}$ N - $\frac{X}{c}$

- a. Contact Gold Plated :
 - 1 : Gold Flash
 - 2 : Gold 30u"
- b. Plastic Color :
 - B : Black
 - W : White
- c. Park selection :
 - D : Disk park

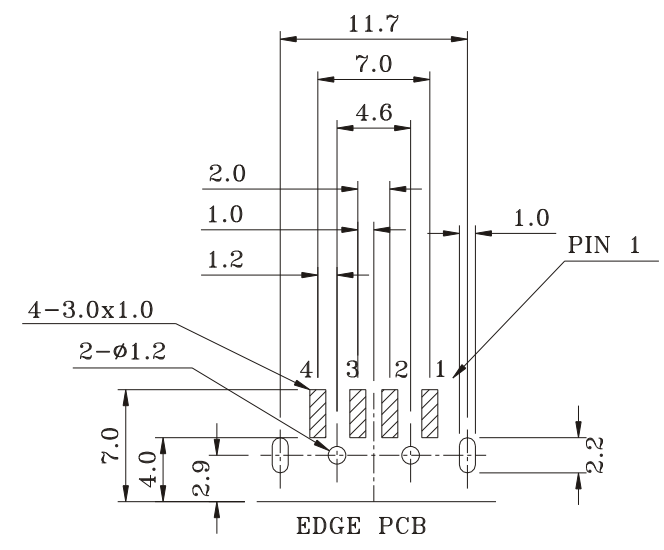
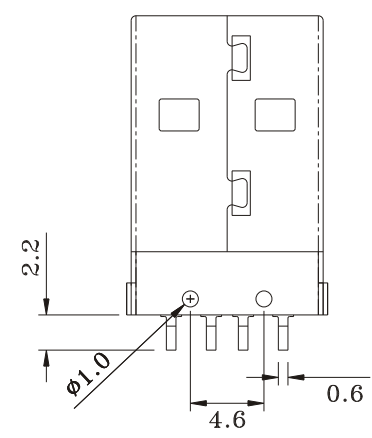
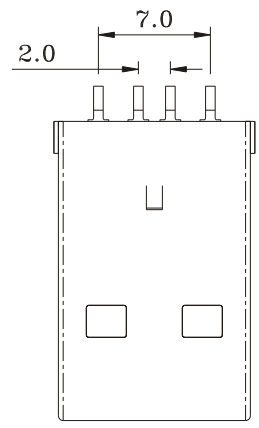
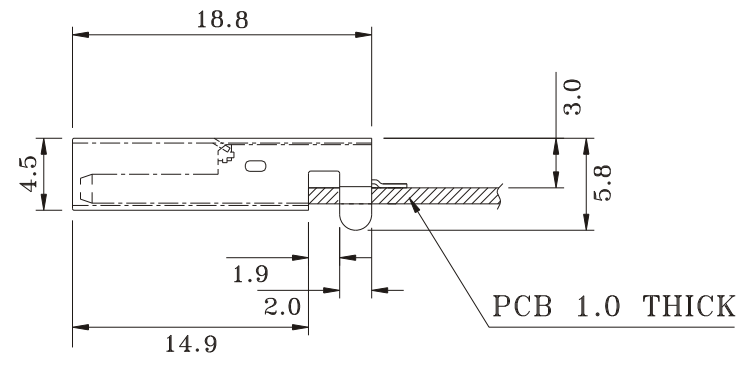
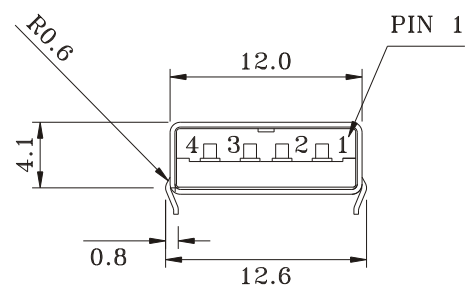

COMPONENT SIDE
(PCB LAYOUT)

NO.	NAME	MATERIAL	FINISH	REMARK	Q'TY
1	HOUSING	NYLON PA9T G.F.	BLACK		1
2	PIN TERM.	BRASS EH T:0.25	GOLD/TIN PLATED	Gold:1~34u" ; Ni:40~604u" ; TIN:120 4u" (100% pure Tin of lead free plating)	4
3	SHELL	BRASS T:0.3	NICKEL PLATED	Ni:2~3u	1

GENAL TOLERANCE ± 0.30	DATE H. D. LI	PART NO SMUSBA1-041-X-XN-X
	DESIGN H. D. LI	TITLE USB TYPE A PLUG FLAT 90度 SMT
	CHECKED Y. M. LU	
UNIT :mm	APPROVED J. F. KANG	宏揚精密有限公司 HOJAR PRECISION CO., LTD.