

ORDER INFORMATION:

H1394 - 061 - $\frac{X}{a}$ - $\frac{X}{b}$ P - $\frac{X}{c}$

- a. Plated selection:
1:Gold 30u"
- b. Plastic selection:
B: BLACK
W: WHITE
- c. Pack selection:
D:Disk Pack

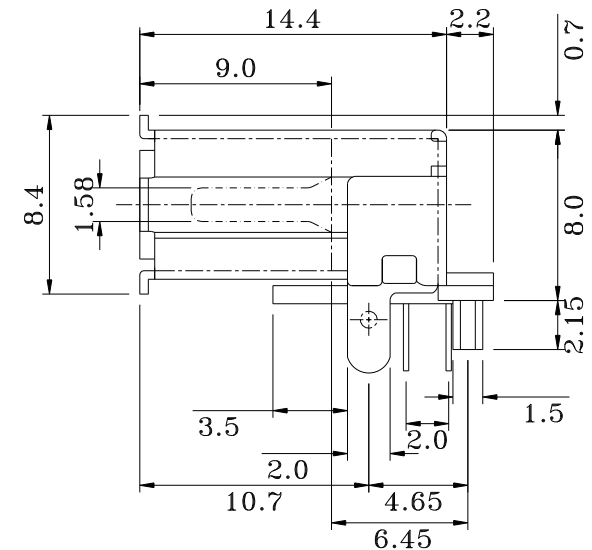
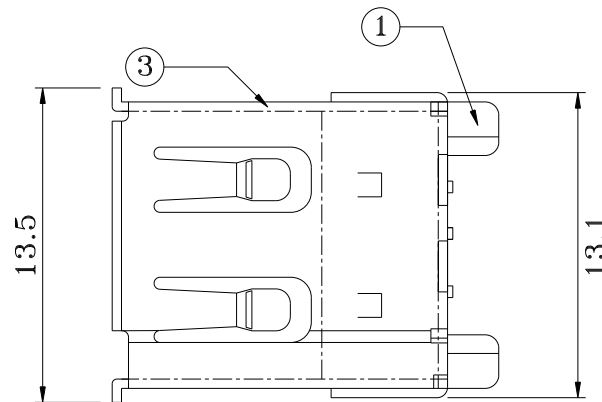
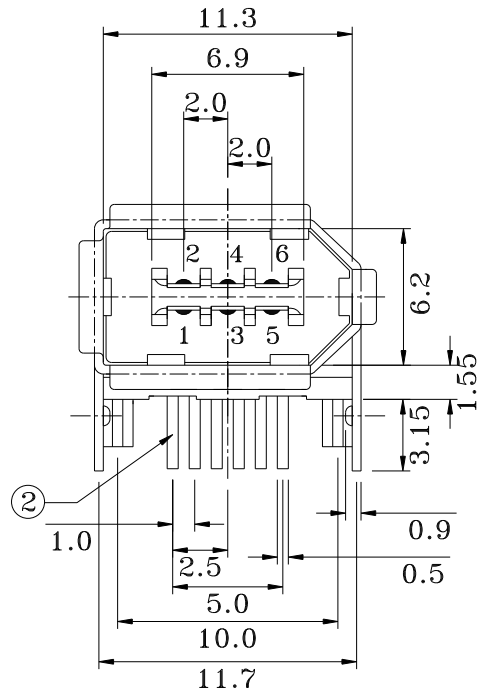
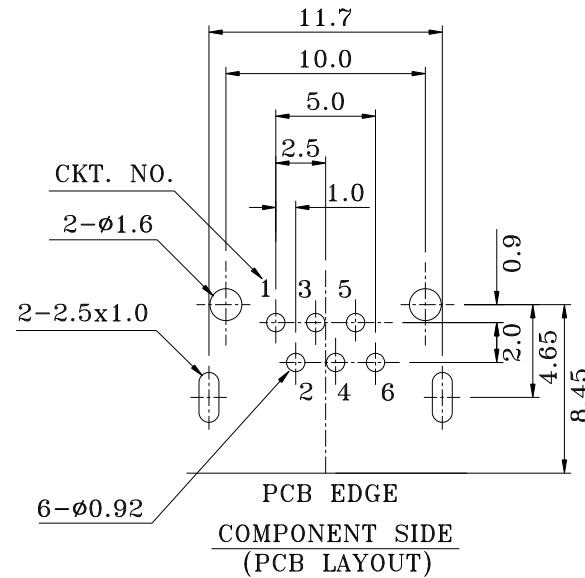

NO.	NAME	MATERIAL	FINISH	REMARK	Q'TY
1	HOUSING	P.B.T. G.F.	BLACK ; WHITE		1
2	PIN TERMINAL	BRASS; t:0.2	GOLD/TIN PLATED	Gold:30 μ " Ni:40~60 μ " TIN:120 μ " (100% pure Tin of lead free plating)	6
3	SHELL	BRASS; t:0.4	NICKEL PLATED	Ni:80~120 μ "	1

GENAL TOLERANCE ± 0.3	DRAW M. C. WANG	PART NO H1394-061-X-XP-X
	DESIGN H. D. LI	TITLE 1394 FLAT 90度 DIP
	CHECKED Y. M. LU	
UNIT :mm	APPROVED J. F. KANG	宏揚精密有限公司 HOJAR PRECISION CO., LTD.