

ORDER INFORMATION:

H1394 - 061 - $\frac{X}{a}$ - S - $\frac{X}{b}$ P - $\frac{X}{c}$

a. Plated selection:
1:Gold 30u"

b. Plastic selection:
B: BLACK

c. Pack selection:
D:Disk Pack

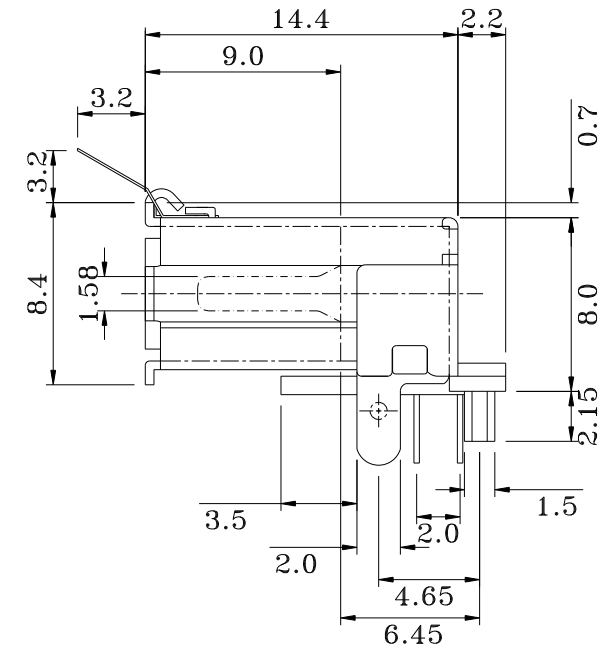
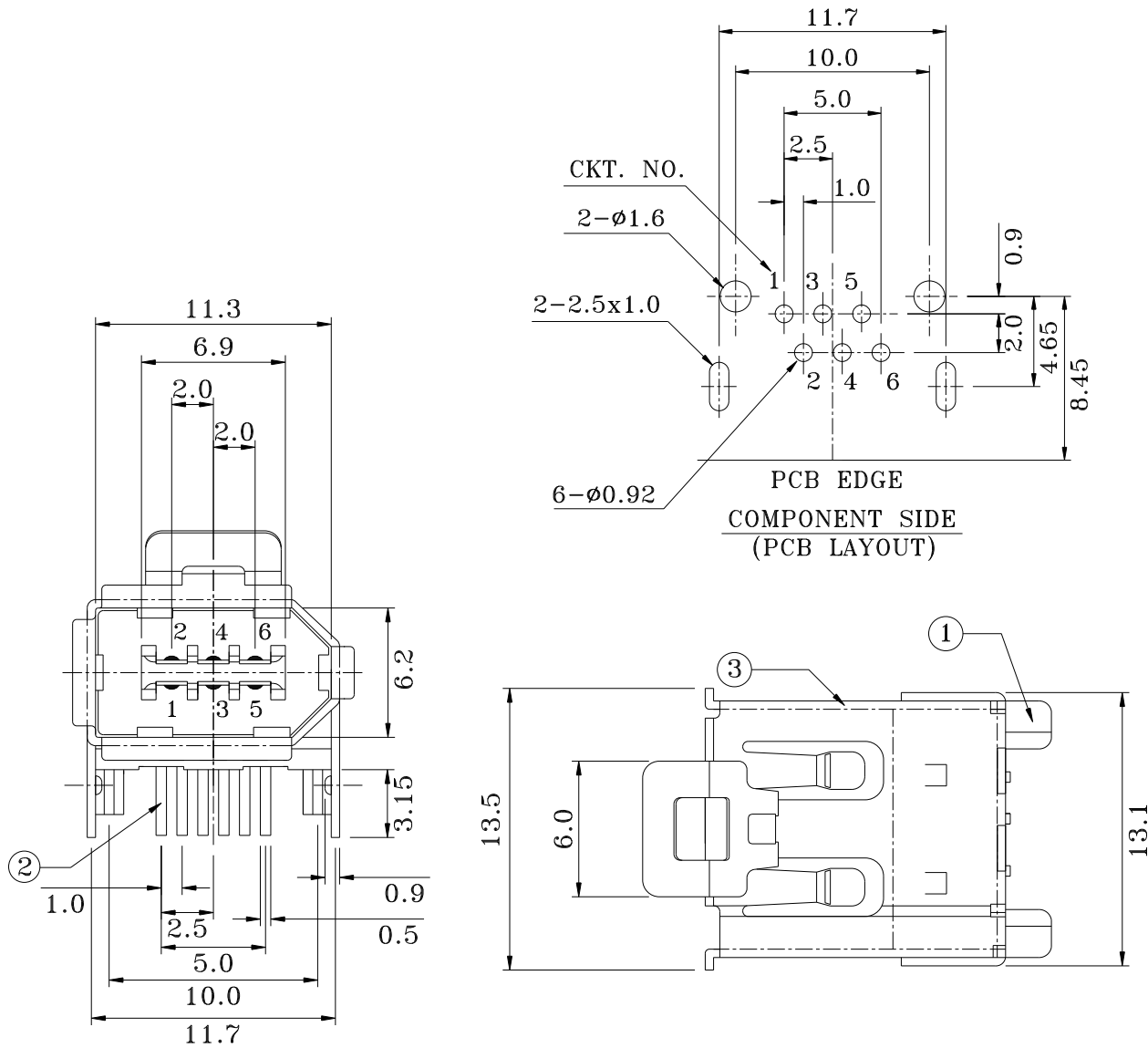

NO.	NAME	MATERIAL	FINISH	REMARK	Q'TY
1	HOUSING	PBT G.F.	BLACK		1
2	PIN TERMINAL	BRASS; t:0.25	GOLD/TIN PLATED	Gold:30u"; Ni:40~60u"; TIN:120u" (100% pure Tin of lead free plating)	6
3	SHELL	BRASS; t:0.4	TIN PLATED	TIN:120~200u"	1
4	SPRING SHIELD	STAINLESS	T:0.1		1

GENAL TOLERANCE ± 0.3	DRAW M. C. WANG	PART NO H1394-061-X-S-XP-X
	DESIGN H. D. LI	TITLE 1394 FLAT 90度 DIP
	CHECKED Y. M. LU	
UNIT :mm	APPROVED J. F. KANG	 宏揚精密有限公司 HOJAR PRECISION CO., LTD.