

ORDER INFORMATION:

SH1394 - 061 - $\frac{X}{a}$ - S - $\frac{XN}{b}$ - $\frac{X}{c}$

- a. Plated selection:
1:Gold 30u"
- b. Plastic selection:
B: BLACK
- c. Pack selection:
D:Disk Pack

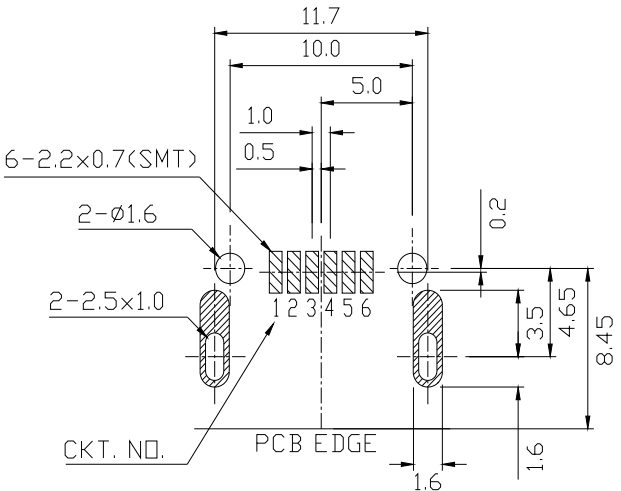

(COMPONENT SIDE)
PCB LAYOUT

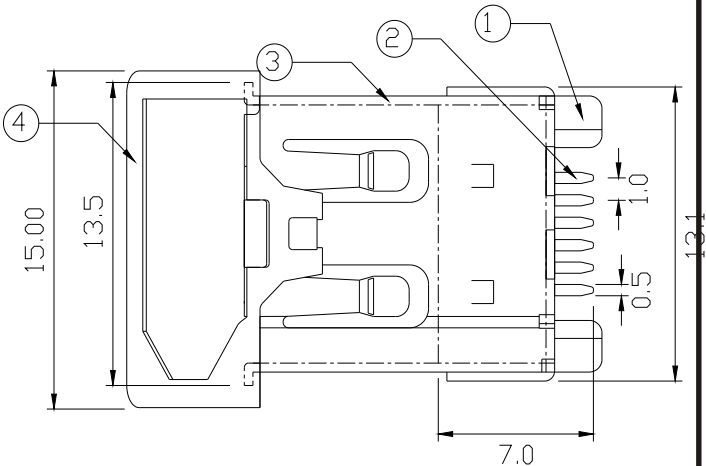
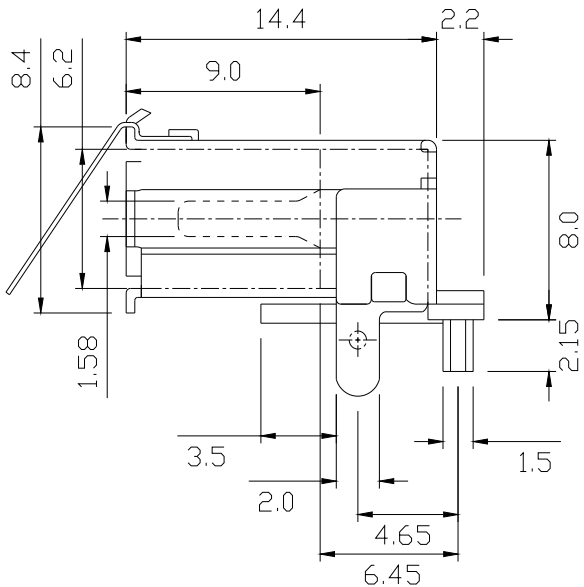
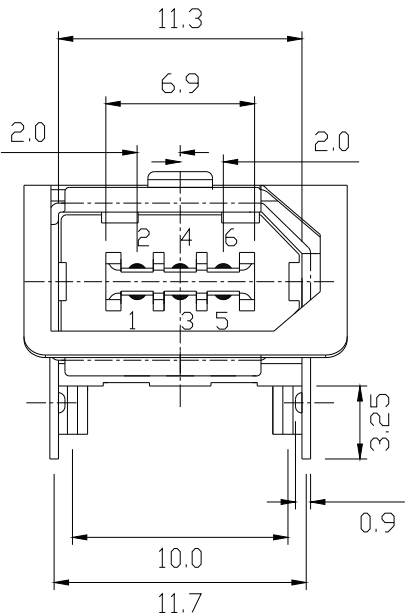

NO.	NAME	MATERIAL	FINISH	REMARK	Q'TY
1	HOUSING	NYLON PA9T G.F.	BLACK		1
2	PIN TERMINAL	BRASS;T:0.25	GOLD/TIN PLATED	Gold:30u"; NI:40~60u"; TIN:120u" (100% pure Tin of lead free plating)	6
3	SHELL	BRASS; T:0.4	NICKEL PLATED	NI:80~120u"	1
4	SPRING SHIELD	STAINLESS T:0.2			1

GENAL TOLERANCE ± 0.3	DRAW M. C. WANG	PART NO SH1394-061-X-S-XN-X
	DESIGN H. D. LI	TITLE 1394 FLAT 90度 SMT
	CHECKED Y. M. LU	
	APPROVED J. F. KANG	
UNIT :mm		宏揚精密有限公司 HOJAR PRECISION CO., LTD.