

ORDER INFORMATION:

SHDMI1 - $\frac{19}{a}$ $\frac{C}{b}$ - $\frac{XX}{c}$ $\frac{XX}{d}$ - $\frac{XX}{e}$ - $\frac{X}{f}$ - $\frac{X}{g}$

Material and Finish:

1. Insulator Material: L.C.P. +30% Glass Filled, UL94V-0, Color: Black
2. Contact Material: Brass (C2680-EH), t=0.2mm
3. Shell Material: Brass (C2680 1/2H), t=0.5mm
4. Contact Area Plated: Selective Gold For One Side
Plated Over 50u" Nickel
5. Solder Area Plated: 100u" Tin Plated For Double Sides
Over 50u" Nickel
6. Current Rating: 0.5 Amp Min.
7. Insulation Resistance: Unmated: 100 Mohms Min.
Mated: 10 Mohms Min.
8. Contact Resistance: 10 mohms Max.
9. Dielectric Withstanding Voltage: 300V AC
10. Operation Temperature: -55°C to +85°C
- ③ 11. Control Dimensions Indicated From ©

- a. Pin of numbers:
19
- b. Shell Type :
C : C=DIP
- c. Contact Plated selection :
1 : Selective Gold Flash
2 : Selective Gold 15u" (Normal)
3 : Selective Gold 30u"
- d. Shell Plated selection :
1 : Nickel (standard)
2 : Gold Flash
- f. Plastic Color :
B : black
- g. Plastic material
L : L.C.P.
- h. Pack selection:
D: Disk Pack
R: Reel Pack

GENERAL TOLERANCE X. ± 0.30 .X ± 0.25 .XX ± 0.20	DRAW 2006/12/25 M. C. WANG	PART NO SHDMI1-19C-XX-XX-X
	DESIGN H. D. LI	TITLE HDMI CONNECTOR RIGHT ANGLE SMD JACK W/O FLANGE
	CHECKED Y. M. LU	
UNIT :mm	APPROVED J. F. KANG	 宏揚精密有限公司 HOJAR PRECISION CO., LTD.

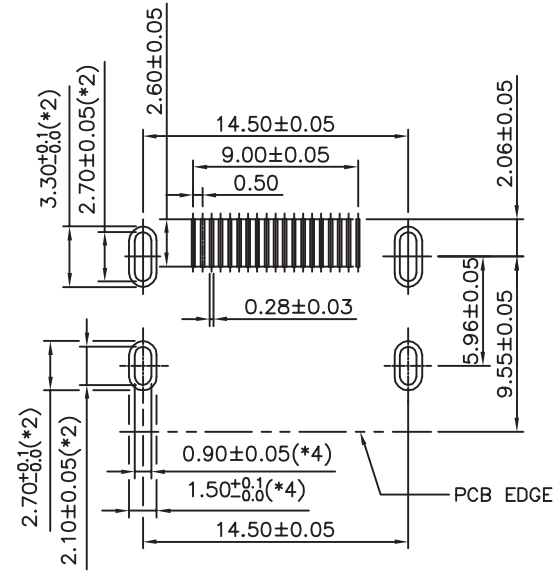
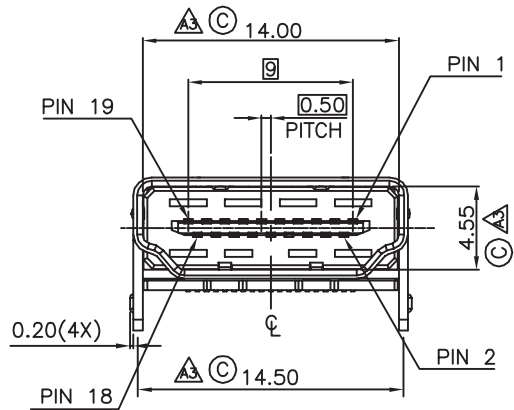
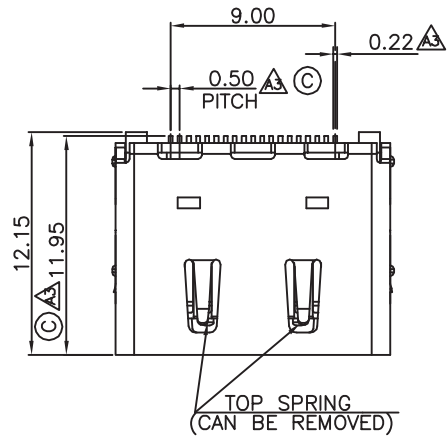
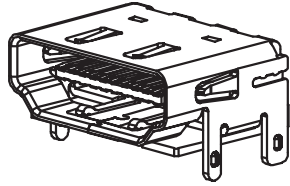

RECOMMENDED PCB LAYOUT (THICKNESS=1.6±0.15mm)

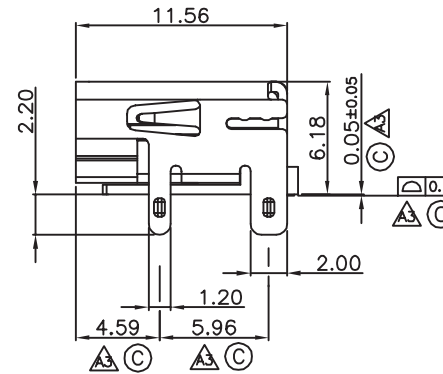

GENAL TOLERANCE X. ± 0.30 .X ± 0.25 .XX ± 0.20	DRAW 2006/12/25 M. C. WANG	PART NO SHDMI1-19C-XX-XX-X
	DESIGN H. D. LI	TITLE HDMI CONNECTOR RIGHT ANGLE SMD JACK W/O FLANGE
	CHECKED Y. M. LU	
UNIT :mm	APPROVED J. F. KANG	 宏揚精密有限公司 HOJAR PRECISION CO., LTD.