

MATERIAL:

INSULATOR : LCP+GLASS FIBER,UL 94V-0.
CONTACT : COPPER ALLOY,T=0.2
CONTACT FINISH : GOLD ON MATING END,MATTE TIN
ON TERMINATION END,WITH ENTIRE
CONTACT NICKEL UNDERPLATED.
SHELL : COPPER ALLOY,NICKEL PLATED.

SPECIFICATION:

CURRENT RATING : 0.5 AMP.
DIELECTRIC WITHSTANDING VOLTAGE : 500V AC FOR 1 MIN.
INSULATION RESISTANCE : 100MΩ MIN.
CONTACT RESISTANCE : 30mΩ MAX.
OPERATING TEMPERATURE : -20°C ~ +85°C.

ORDER INFORMATION:

SHDMI2 - $\frac{19}{a}$ - $\frac{A}{b}$ - $\frac{XX}{c}$ - $\frac{S}{d}$ - $\frac{XX}{e}$ - $\frac{X}{f}$ - $\frac{X}{g}$

- a. Pin of numbers:
19
- b. Shell Type :
A : SHORT TYPE
- c. Contact Plated selection :
1 : Selective Gold 15u"
2 : Selective Gold 30u" (Normal)
3 : Contace area:30u" Gold
Tail area: Gold flash
- d. Shell Plated selection :
1 : Nickel (standard)
2 : Bright Tin
3 : Gold
4 : Matte Tin
- f. Plastic Color :
B : black
- g. Plastic material
L : L.C.P.
- h. Pack selection:
D: Disk Pack
R: Reel Pack

GENAL TOLERANCE .X ± 0.25 .XX ± 0.15 .XXX ± 0.05	DRAW 2006/12/25 M. C. WANG	PART NO SHDMI2-19A-XX-S-XX-X
	DESIGN H. D. LI	TITLE HDMI CONNECTOR RIGHT ANGLE SMD JACK SHORT TYPE WITH FLANGE
	CHECKED Y. M. LU	
UNIT :mm	APPROVED J. F. KANG	 宏揚精密有限公司 HOJAR PRECISION CO., LTD.

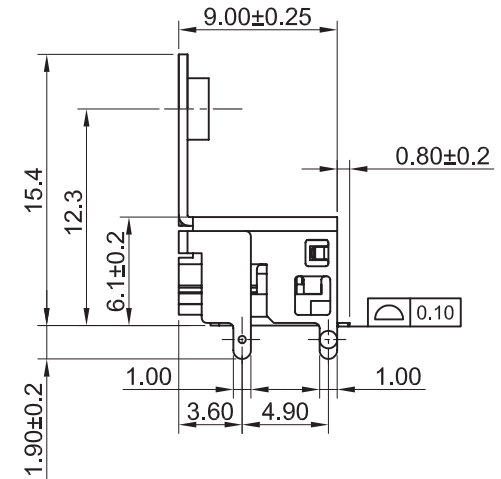
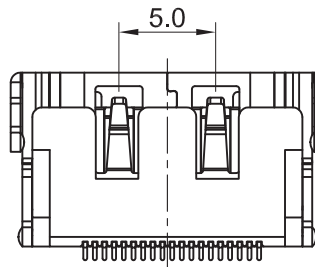
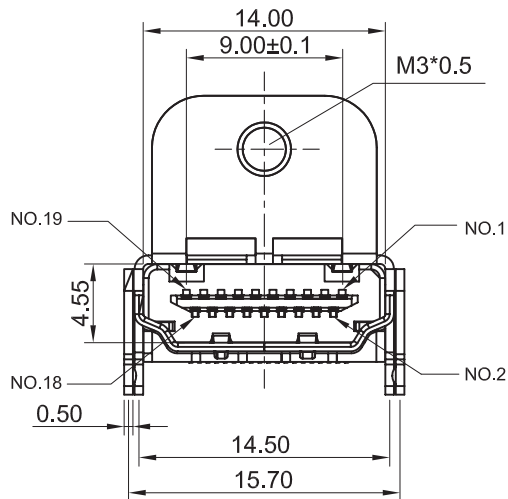
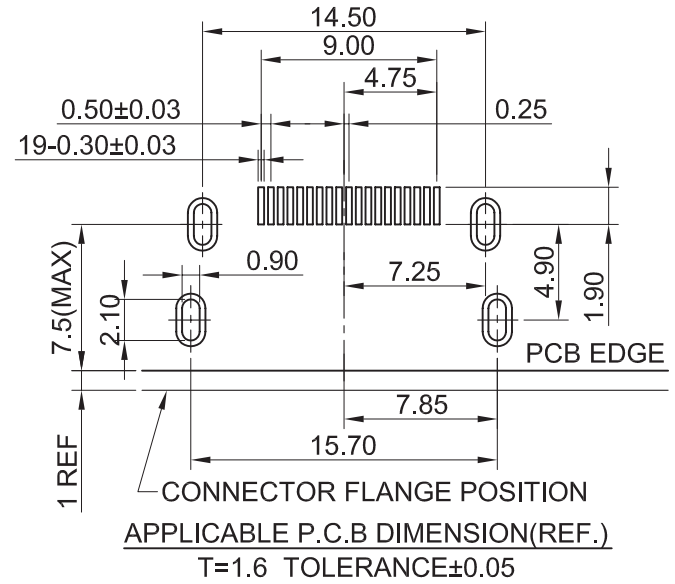
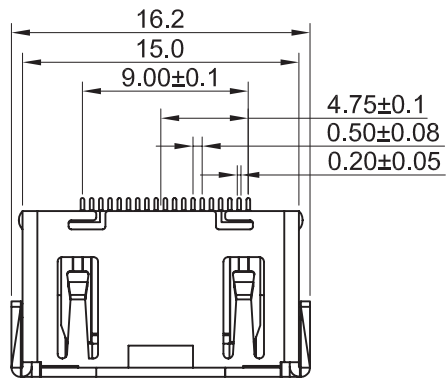

GENERAL TOLERANCE .X ± 0.25 .XX ± 0.15 .XXX ± 0.05	DRAW 2006/12/25 M. C. WANG	PART NO SHDMI2-19A-XX-S-XX-X
	DESIGN H. D. LI	TITLE HDMI CONNECTOR RIGHT ANGLE SMD JACK SHORT TYPE WITH FLANGE
	CHECKED Y. M. LU	
	APPROVED J. F. KANG	
UNIT :mm		 宏揚精密有限公司 HOJAR PRECISION CO., LTD.