

SPECIFICATIONS

Current Rate: 5 Amps

Insulator Resistance : 1000M Ω Min at 500V DC

Dielectric Strength : 1000V Per minute

Operation Temperature : -55°C ~ +105°C

MATERIAL

Insulator : P.B.T +30% Brass Fiber (UL94V-0)

Contact : Brass

Contact Plated : Gold Over Nickel

Shell : Steel, Zinc plated or Tin plated

ORDER INFORMATION:

FDSUB - 25 2 - $\frac{X}{a}$

a. Pack :

D : Disk Pack

VERSION & EC DESCRIPTION

DATE	VERSION	PAGE	DESCRIPTION
2005/02/24	A	20-21	Add FDSUB - 25 2 - X Plan

GENAL TOLERANCE	DRAW DATE	2005/02/24	PART NO
.X \pm 0.5	H. D. LI		FDSUB - 25 2 - X
.XX \pm 0.30	DESIGN	H. D. LI	TITLE
.XXX \pm X.XX	CHECKED	Y. M. LU	D-SUB Female 25Pin 叉卯
	APPROVED	J. F. KANG	 宏揚精密有限公司 HOJAR PRECISION CO. : LTD.
UNIT :mm			

VERSION

A

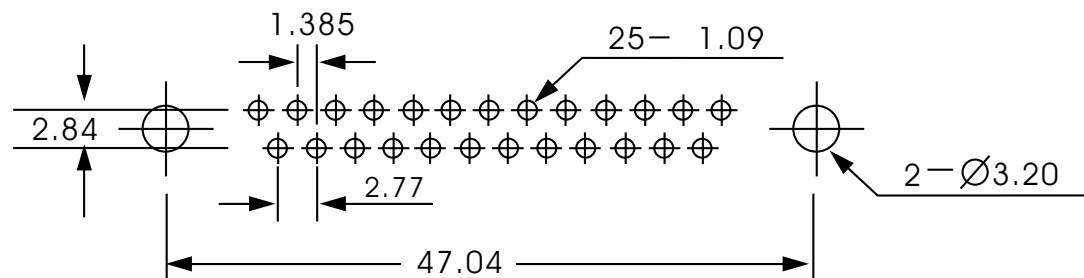
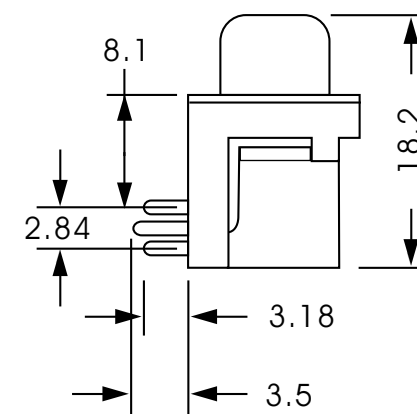
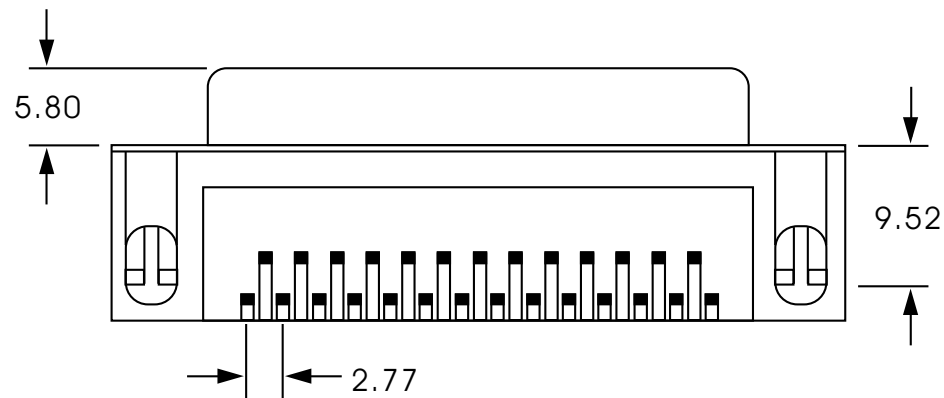
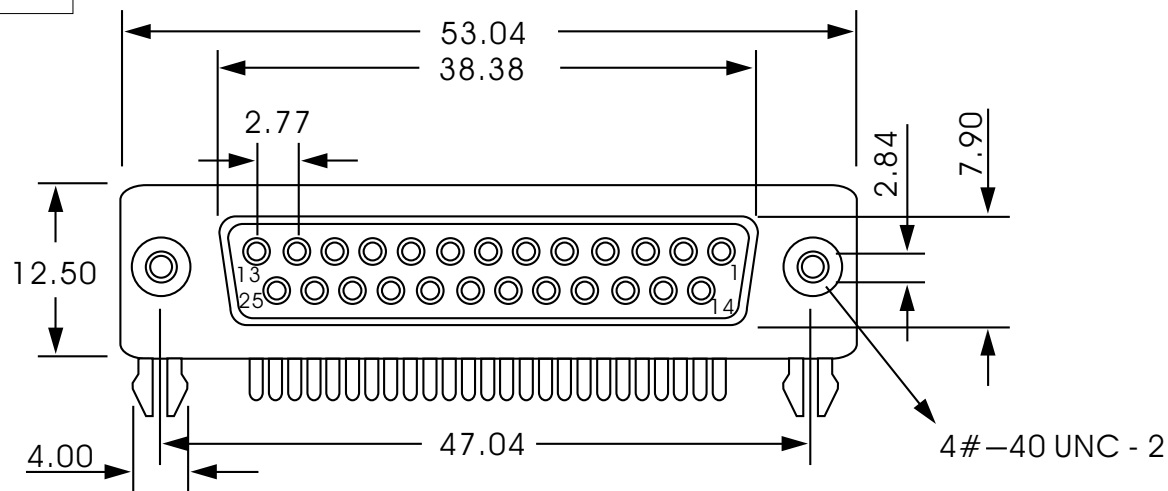

P.C.B LAYOUT

GENERAL TOLERANCE .X ± 0.5 .XX ± 0.30 .XXX ± X.XX	DRAW DATE 2005/02/24 H. D. LI	PART NO FDSUB - 25 2 - X
	DESIGN H. D. LI	TITLE D-SUB Female 25Pin 叉卯
	CHECKED Y. M. LU	
	APPROVED J. F. KANG	
UNIT :mm		 宏揚精密有限公司 HOJAR PRECISION CO. : LTD.