

VERSION

A

ORDER INFORMATION:

USBM1 -  $\frac{5}{a}$   $\frac{1}{b}$  - 0  $\frac{D}{c}$

- a. Pin No. : 5
- b. Plastic Type :
- c. Pack Selection :
- D : Disk Pack

VERSION & EC DESCRIPTION			
DATE	VERSION	PAGE	DESCRIPTION
2005/03/14	A	2-3	Add USBM1-51-0D Plan

GENAL TOLERANCE	DRAW DATE	2006/05/24	PART NO
X. ± X.XX	H. D. LI		USBM1-51-0D
.X ± X.XX	DESIGN	H. D. LI	TITLE
.XX ± X.XX	CHECKED	Y. M. LU	USB MINI B CONNECTOR
.XXX ± X.XX	APPROVED	J. F. KANG	CONTACT-DIP, SHIELD-DIP
UNIT :mm			 宏揚精密有限公司 HOJAR PRECISION CO., LTD.

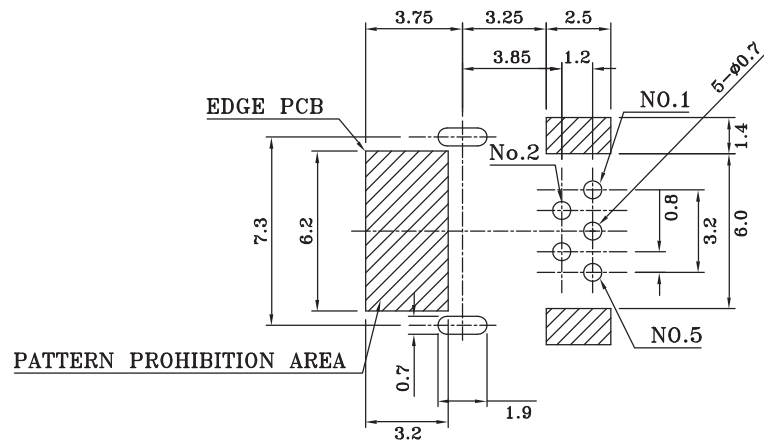

RECOMMENDED PCB PATTERN LAYOUT  
(PCB THICKNESS:0.8±0.1)

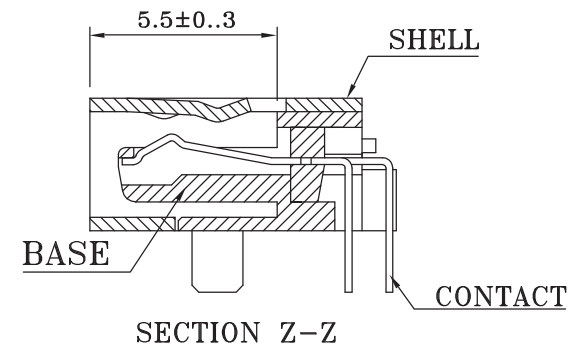
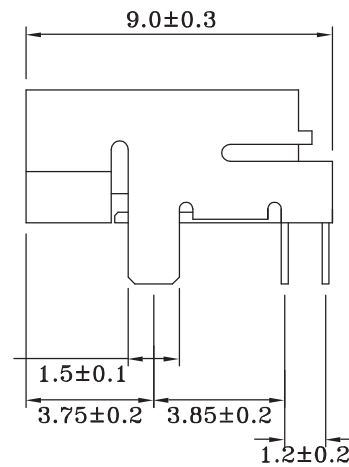
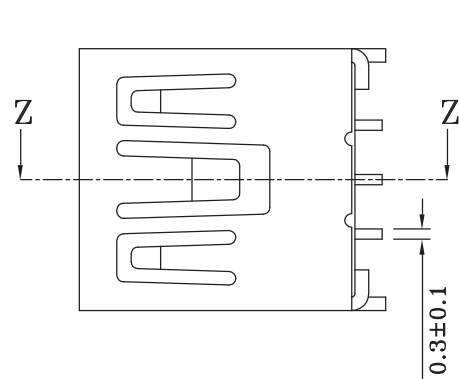
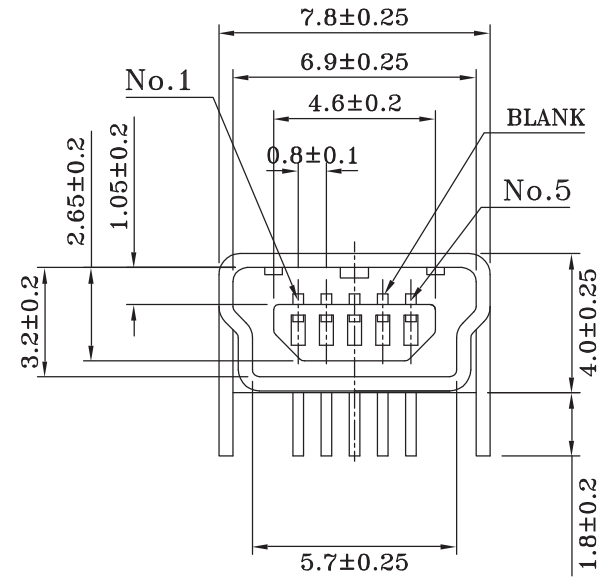

NO.	NAME	MATERIAL	FINISH	REMARK	Q'TY
1	HOUSING	NYLONPA9TG.F	BLACK		1
2	PINTERM.	PBST:0.2	GOLD/TINPLATED	Gold:30u"; Ni:40~60u"; TIN:120u" (100 pureTinfoleadfreeplating)	5
3	SHELL	BRASST:0.4	NICKELPLATED	NI:80~120u"	1

GENAL TOLERANCE X. ± X.XX .X ± X.XX .XX ± X.XX .XXX ± X.XX	DRAW 2006/05/24 DATE H. D. LI	PART NO USBM1-51-0D
	DESIGN H. D. LI	TITLE USB MINI B CONNECTOR CONTACT-DIP, SHIELD-DIP
	CHECKED Y. M. LU	
UNIT :mm	APPROVED J. F. KANG	 宏揚精密有限公司 HOJAR PRECISION CO., LTD.