

ORDER INFORMATION:

SUSBM3 - 051 - $\frac{XX}{a} - \frac{XX}{c} - \frac{X}{d} - \frac{X}{e}$

SPECIFICATION:

1.ELECTRICAL

Voltage Rating:30V AC;
 Current Rating:1A;
 Insulation Resistance:50MΩ Min;
 Contact Resistance:40mΩ Max;
 Dielectric Withstanding Voltage: AC 500V;
 Operating Temperature Range:-30°C To +85°C.

2.MECHANICAL

Total Insertion Force:3.50kgf Max;
 Total Pulling Force:0.8~2.0kgf Min;
 DURABILITY:10000 Cycles.

3.MATERIAL:

Housing:HI-TEMP Plastic,UL94V-0;
 Contact:Copper Alloy,T=0.15mm;
 Shell:Copper Alloy,T=0.25mm;

4.FINISH:

Contact area:(Min) 0.75um Au on top of (Min) 2.0um Ni;
 Solder tail:(Min) 0.05um Au on top of (Min) 2.0um Ni.

a. Plated selection :

- 1 : Gold Flash
- 2 : Gold 30u"

b. 外殼:

T:鍍霧錫

c. Plastic Color :

B : Black

d. Plastic material :

L : LCP (standard)

e. Pack selection:

- T : Tube Pack
- R : Reel Pack

GENAL TOLERANCE X. ± 0.38 .X ± 0.30 .XX ± 0.25 .XXX± 0.10	DATE	H. D. LI	PART NO
	DESIGN	H. D. LI	SUSBM3-051-XX-XX-X
	CHECKED	Y. M. LU	TITLE
	APPROVED	J. F. KANG	Micor USB 5 P FEMALE
UNIT :mm			 宏揚精密有限公司 HOJAR PRECISION CO., LTD.

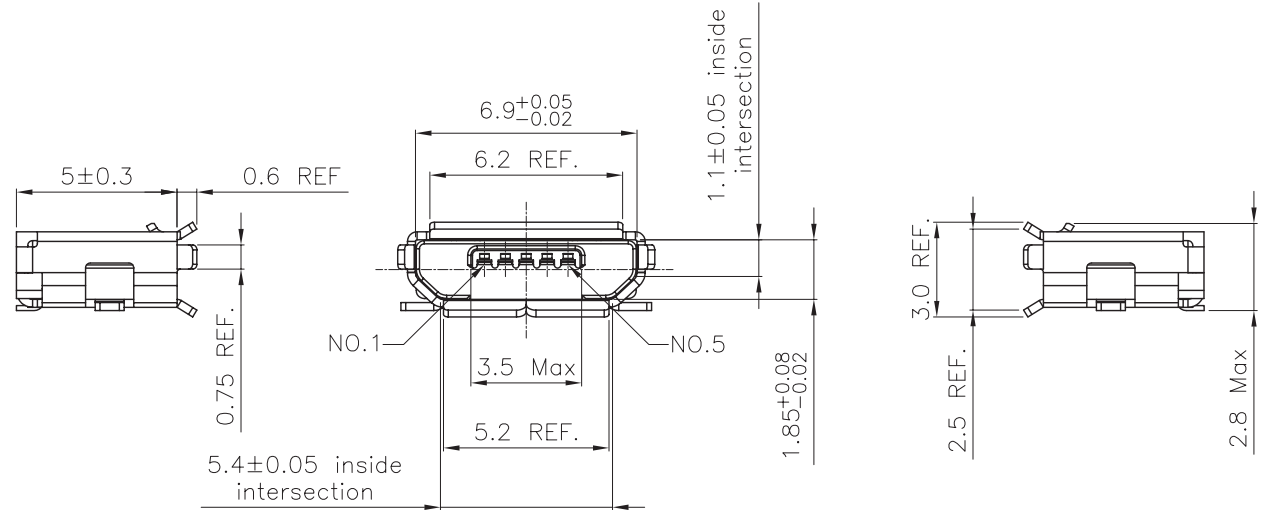
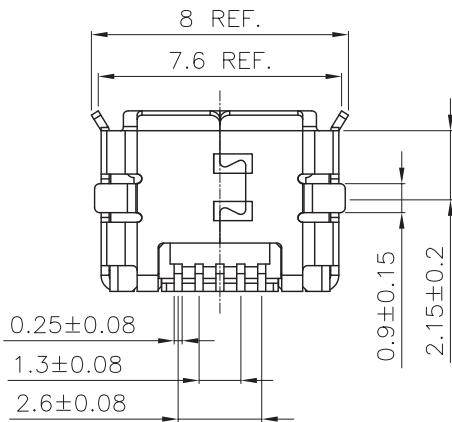
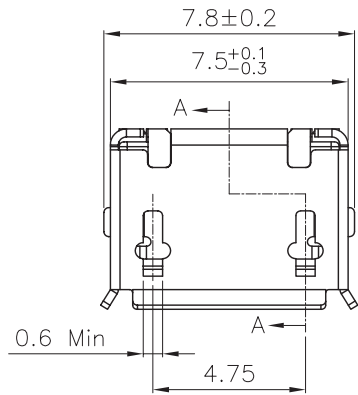
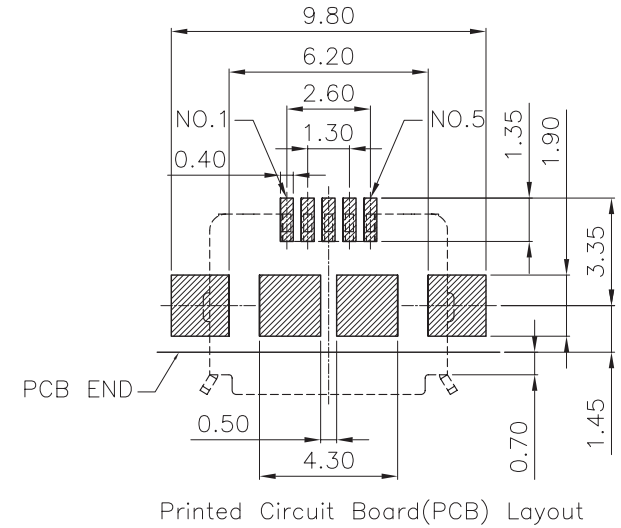
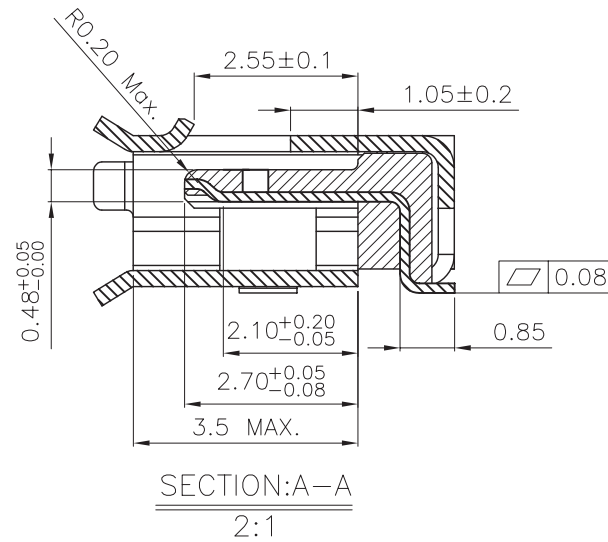
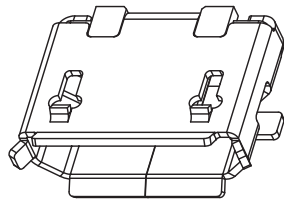

GENAL TOLERANCE X. ± 0.38 .X ± 0.30 .XX ± 0.25 .XXX ± 0.10	DATE H. D. LI	PART NO SUSBM3-051-XX-XX-X
	DESIGN H. D. LI	TITLE Micor USB 5P FEMALE
	CHECKED Y. M. LU	
UNIT :mm	APPROVED J. F. KANG	宏揚精密有限公司 HOJAR PRECISION CO., LTD.