

SPECIFICATIONS

Current Rating : 3 Amp

Insulator resistance : 1000 Meg ohms At DC 500V

Contacts resistance : 25 m ohms max.

Dielectric withstanding : AC 1000V min per minute

Operating Temperature : -55° — +85 C°

Contact insertion Force : 1 kg max

Contact Seproton Force : 70 g min

MATERIAL

Insulator : P.B.T +15% G.F UL-94V-O

Contact : Phosphor Bronze

Plating : Gold Or Nickel Plated

VERSION & EC DESCRIPTION			
DATE	VERSION	PAGE	DESCRIPTION
2004/09/07	A	2-3	Add HJM2-021-1-C Plan

GENAL TOLERANCE	DRAW DATE	2004/09/07 H. D. LI	PART NO
X. ± X.XX	DESIGN	H. D. LI	HJM2-021-1-C
.X ± 0.20	CHECKED	Y. M. LU	TITLE
.XX ± 0.10	APPROVED	J. F. KANG	Pitch 2.00mm Mini Jumper Close
.XXX ± X.XX	UNIT :mm		 宏揚精密有限公司 HOJAR PRECISION CO. : LTD.

VERSION

A

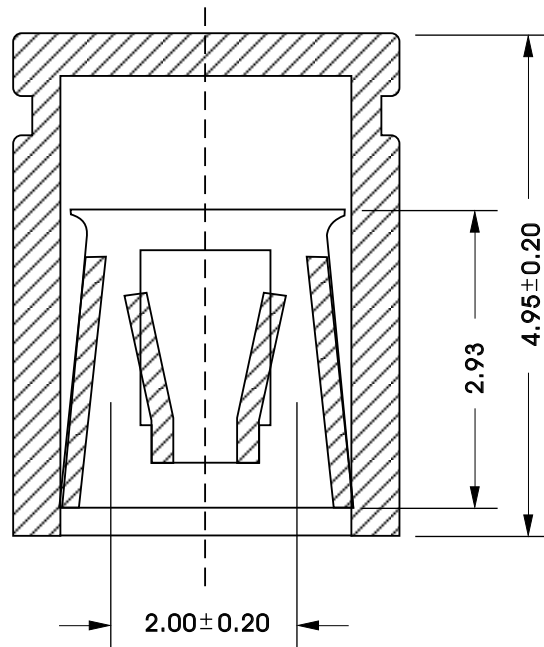

SEC A - A

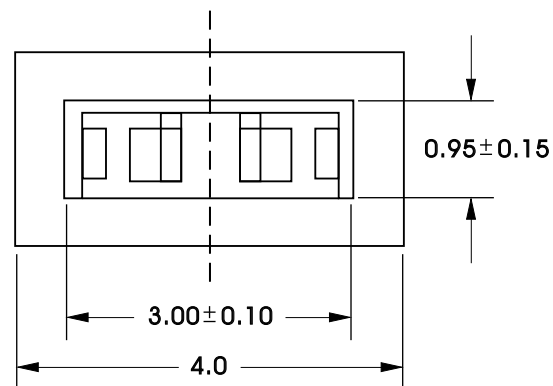
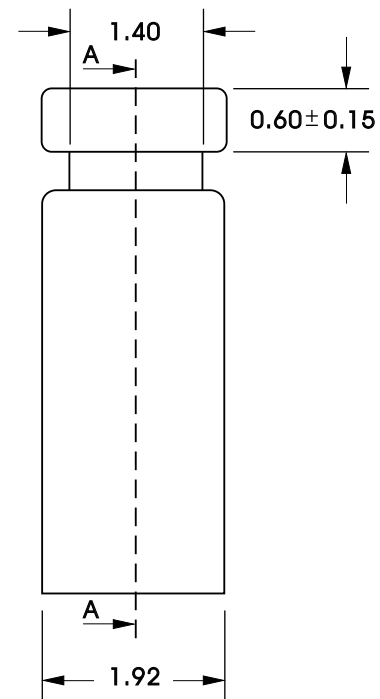

GENERAL TOLERANCE	DRAW DATE	2004/09/07 H. D. LI	PART NO
X. ± X.XX	DESIGN	H. D. LI	HJM2-021-1-C
.X ± 0.20	CHECKED	Y. M. LU	TITLE
.XX ± 0.10	APPROVED	J. F. KANG	Pitch 2.00mm Mini Jumper Close
.XXX ± X.XX			
UNIT :mm			 宏揚精密有限公司 HOJAR PRECISION CO. : LTD.