

## ORDER INFORMATION:

DMD2-  $\frac{66}{a}$  -  $\frac{S}{b}$  -  $\frac{XP}{cd}$  -  $\frac{D}{e}$

- a. Pos NO:  
66:6P x 6P
- b. Shell option:  
S: FULLY SHIELDED & SPRING WITH KINK
- c. Housing color:  
1:Black  
2:TOP--GREEN,3995C  
BOTTOM--PURPLE,2715C
- d. Insulator material:  
P:PBT
- e. Pack selection:  
D:Disk Pack

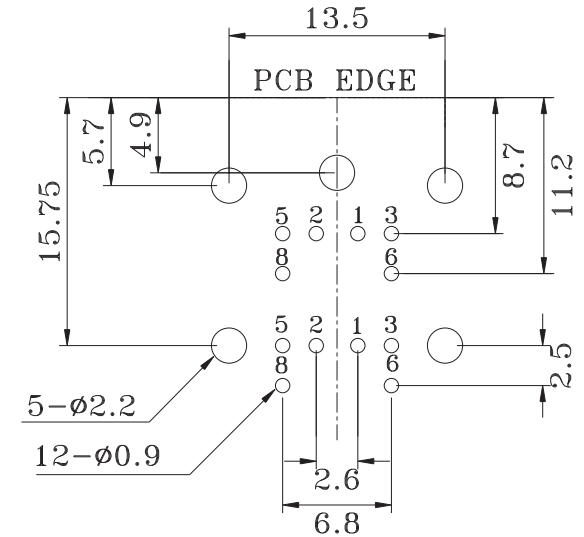

PCB LAYOUT  
(BOTTOM VIEW)

NO.	NAME	MATERIAL	FINISH	REMARK	Q'TY
1	TOP HOUSING	P.B.T.	BLACK		1
2	BOTTOM HOUSING	P.B.T.	BLACK		1
3	BACK COVER	P.B.T.	BLACK		1
4	CONTACT TERM.	PHOS. BRONZE	GOLD/TIN PLATED	Gold:1~3μ"; NI:40~60μ" ; TIN:120μ" (100% pure Tin of lead free plating)	12
5	FRONT SHIELD	BRASS	TIN PLATED	TIN:3~5u	1
6	BACK SHIELD	BRASS	TIN PLATED	TIN:3~5u	1
7	GROUND SHIELD	STAINLESS	0.2 THK		1

GENAL TOLERANCE ± 0.30	DATE H. D. LI	PART NO DMD2-66-S-XP-D
	DESIGN H. D. LI	TITLE SHIELDED DUBLE MINI DIN WITH KINK TYPE
	CHECKED Y. M. LU	
	APPROVED J. F. KANG	
UNIT :mm		宏揚精密有限公司 HOJAR PRECISION CO., LTD.