

ORDER INFORMATION:

SEAR12 - 051 $\frac{X}{a}$ - $\frac{X}{b}$ - $\frac{A/B/C}{c}$ - $\frac{X}{d}$

- a. SCHEMATIC:
A~D
- b. Post selection:
1: with post
- c. Length/Width/Height:
A/B/C (A=12.0,B=9.0,C=4.1) (standard)
- d. Pack selection:
R:Reel Pack

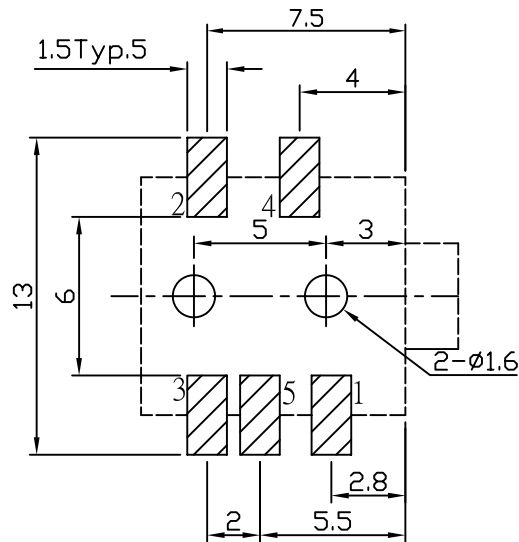

SCHEMATIC			
SEAR12-051A	SEAR12-051B	SEAR12-051C	SEAR12-051D

T:1.6 Dimensions of PC board holes
Tolerance : ±0.1(Printed-top view)

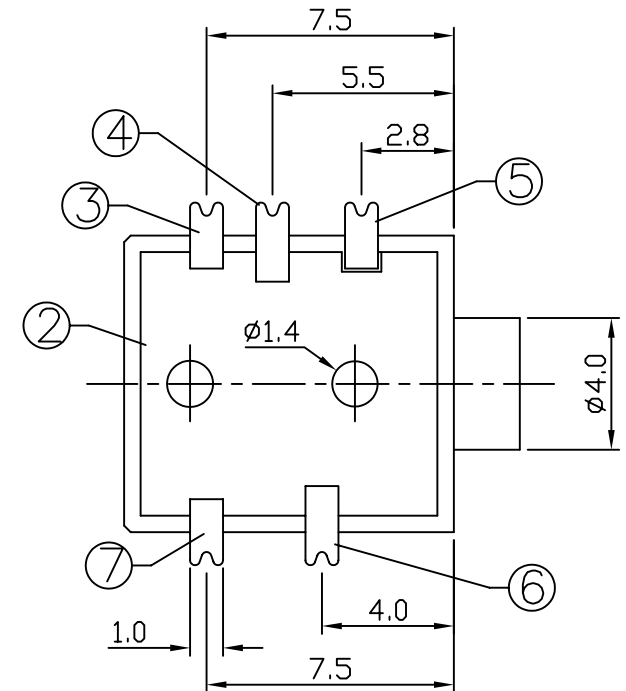
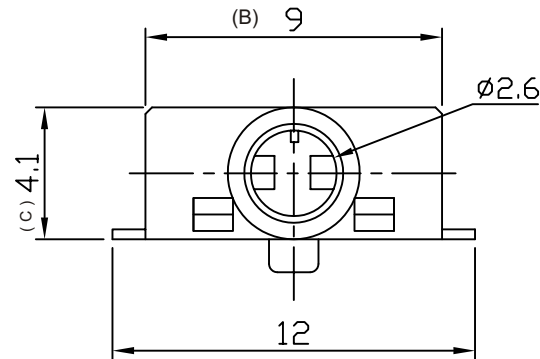
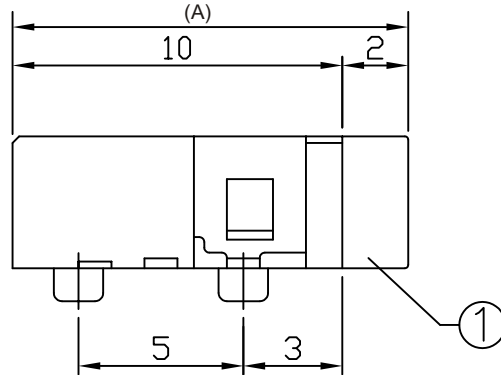

7	SPRING PIECE	1	PHOSPHOR BRONZE	MB:Cu	Ag	PLATED
6	CURVE PIECE	1	BRASS	MB:Cu	Ag	PLATED
5	CONTACT	1	PHOSPHOR BRONZE	MB:Cu	Ag	PLATED
4	FOOT	1	BRASS	MB:Cu	Ag	PLATED
3	SPRING PIECE	1	PHOSPHOR BRONZE			
2	COVER	1	FR52			
1	HOUSING	1	FR52			
LTR	PART NAME	QTY	MATERIAL	REMARK		

GENAL TOLERANCE ± 0.2	DRAW M. C. WANG	PART NO SEAR12-051X-X-A/B/C-X
	DESIGN H. D. LI	TITLE 2.5MM MINIATURE JACK (SMT)
	CHECKED Y. M. LU	
	APPROVED J. F. KANG	
UNIT :mm		宏揚精密有限公司 HOJAR PRECISION CO., LTD.