

ORDER INFORMATION:

MATERIAL

Insulator:PBT+30%Glass Fiber (UL94V-0)
 Contact: Brass
 Contact Plated:Gold or Tin Plated
 Shell:Steel,Nickel Plated
 Screw: Brass ,Nickel Plated

SPECIFICATION

Current Rate:5 Amps
 Insulator Resistance:5000M Ω Min. at 500V DC
 Dielectric Strength:1000V Per minute
 Operation Temperature:-55°C to+105°C

FDSUB - 154 - H/D $\frac{-X}{a}$ $\frac{X}{b}$ - $\frac{X}{c}$

- a. Plastic Color :
 - 1:全金藍
 - 2:半金藍
 - 3:全金黑
 - 4:半金黑
- b. Plastic Material :
 - P:PBT
- c. Pack :
 - D : Disk Pack

GENAL TOLERANCE .X ± 0.5 .XX ± 0.30 .XXX ± X.XX ANG ± 2°	DRAW 2005/02/24 DATE H. D. LI	PART NO FDSUB-154-H/D-XX-X
	DESIGN H. D. LI	TITLE HDR15P8.89母又卯鎖黑 3.18 鎖螺絲5.80#11.8 無毒
	CHECKED Y. M. LU	
UNIT :mm	APPROVED J. F. KANG	 宏揚精密有限公司 HOJAR PRECISION CO., LTD.

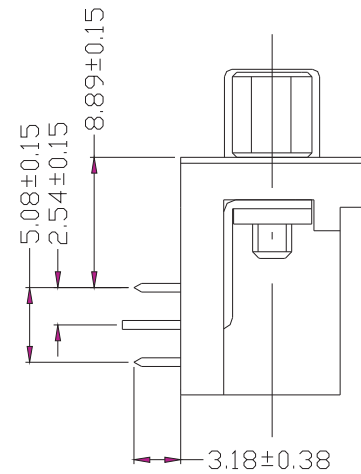
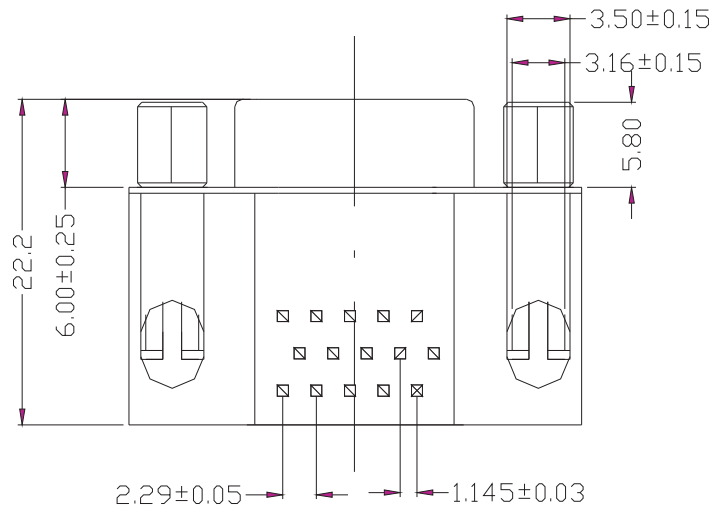
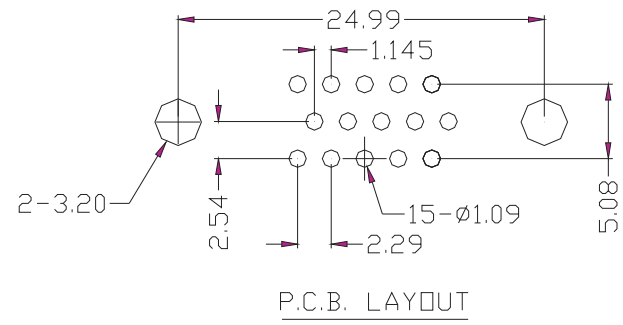
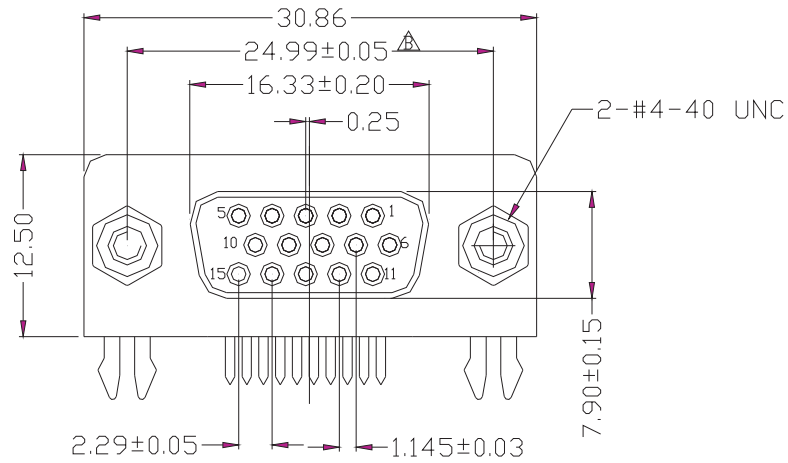

GENAL TOLERANCE .X ± 0.5 .XX ± 0.30 .XXX $\pm X.XX$ ANG $\pm 2^\circ$	DRAW DATE 2005/02/24 H. D. LI	PART NO FDSUB-154-H/D-XX-X
	DESIGN H. D. LI	TITLE HDR15P8.89母又卯鎖黑 3.18 鍍螺絲5.80*11.8 無毒
	CHECKED Y. M. LU	
UNIT :mm	APPROVED J. F. KANG	 宏揚精密有限公司 HOJAR PRECISION CO., LTD.