

ORDER INFORMATION:

SUSBM2 - 101 - $\frac{XX}{a} - \frac{XX}{c} - \frac{X}{d} - \frac{X}{e}$

Specification

*Electrical Characteristics:

Contact Current Rating:0.3 Amperes.
 Dielectric Withstanding Voltage:AC 500V R.M.S.
 Insulation Resistance:1000MΩ Min.
 Contact Resistance:40mΩ Max.

*Environmental:

Operating Temperature:-25°C~+70°C.

*Material:

Housing:LCP UL94V-0
 Contact:Brass(t=0.20mm),Contact area
 Plating Au 1U",3U",5U",10U',15U",30U",
 Plating Tin 80U" Min on Solder Tails
 Shell:Brass(t=0.25mm),Plating Nickel Over all.

a. Plated selection :

- 1 : Gold 1u"
- 2 : Gold 3u"
- 3 : Gold 5u"
- 4 : Gold 10u"
- 5 : Gold 15u"
- 6 : Gold 30u"

b. 外殼:

T:鍍霧錫
 N:鍍鎳錫

c. Plastic Color :

B : Black

d. Plastic material :

L : LCP (standard)

e. Pack selection:

T : Tube Pack
 R : Reel Pack

GENAL TOLERANCE X. ± 0.1 .X ± 0.05 .XX ± 0.02 .XXX± 0.005	DATE	H. D. LI	PART NO
	DESIGN	H. D. LI	SUSBM2-101-XX-XX-X
	CHECKED	Y. M. LU	TITLE
	APPROVED	J. F. KANG	MINI USB 10P L:8.5 (SMT)
UNIT :mm			 宏揚精密有限公司 HOJAR PRECISION CO., LTD.

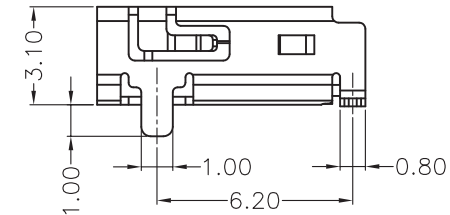
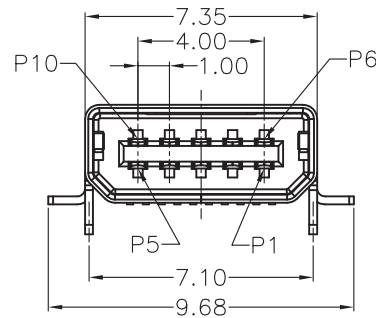
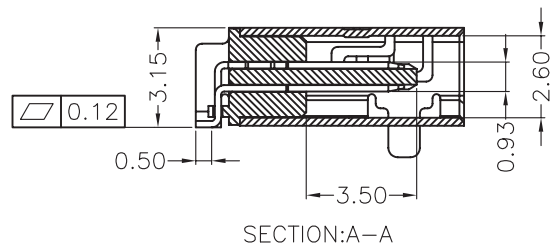
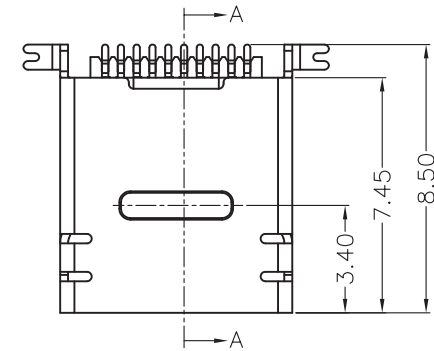
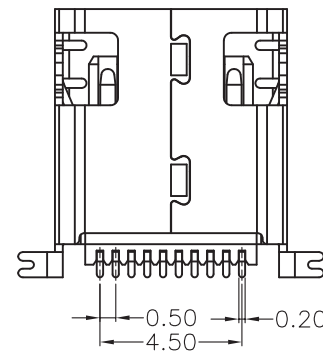
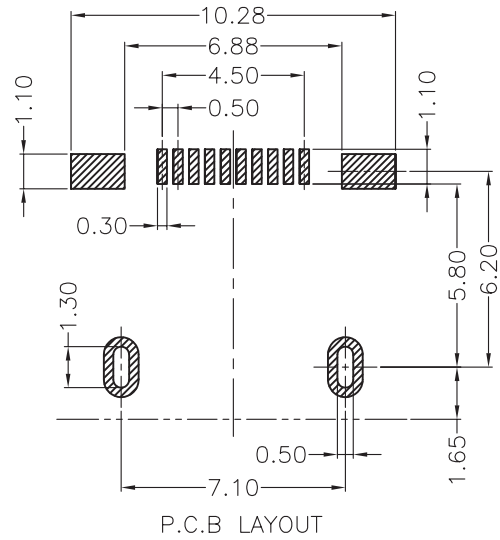
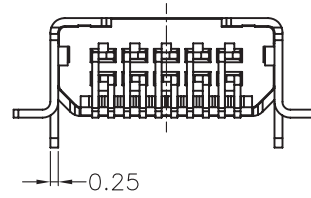

GENAL TOLERANCE X. ± 0.1 .X ± 0.05 .XX ± 0.02 .XXX± 0.005	DATE H. D. LI	PART NO SUSBM2-101-XX-XX-X
	DESIGN H. D. LI	TITLE MINI USB 10P L:8.5 (SMT)
	CHECKED Y. M. LU	
UNIT :mm	APPROVED J. F. KANG	 宏揚精密有限公司 HOJAR PRECISION CO., LTD.