

ORDER INFORMATION:

SEAR12 - 062X - X - A/B/C - X
 $\frac{a}{b} \frac{c}{d}$

- a. SCHEMATIC:
A~D
- b. Post selection:
1: with post
- c. Length/Width/Height:
A/B/C (A=12.0,B=7.0,C=3.2) (standard)
- d. Pack selection:
R:Reel Pack

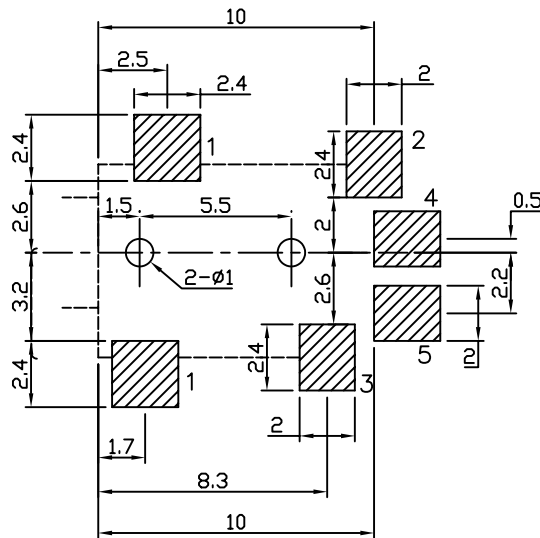

SCHEMATIC			
SEAR12-062A	SEAR12-062B	SEAR12-062C	SEAR12-062D

T:1.6 Dimensions of PC board holes
 Tolerance : ±0.1(Printed-top view)

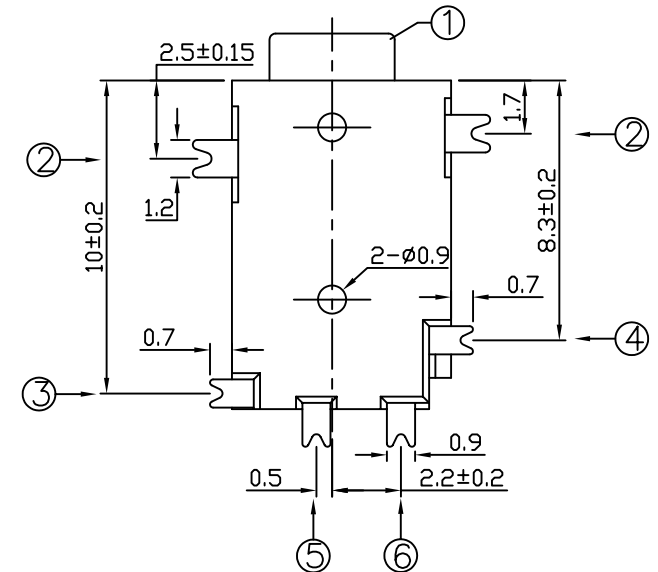
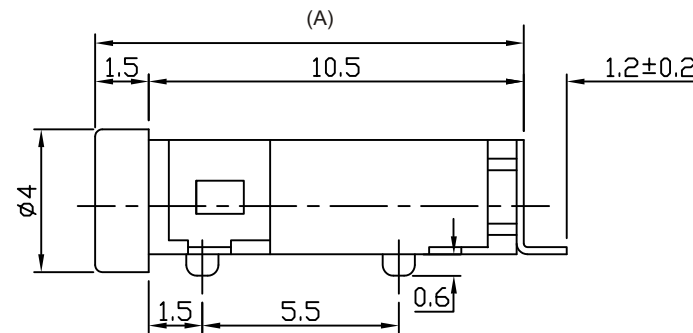
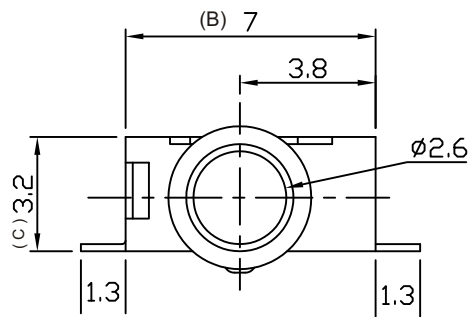

6	CONTACT FOOT	1	PHOSPHOR BRONZE	MB:Cu Ag PLATED
5	CONTACT FOOT	1	PHOSPHOR BRONZE	MB:Cu Ag PLATED
4	SPRING PIECE	1	Be-Cu	MB:Cu Ag PLATED
3	SPRING PIECE	1	Be-Cu	MB:Cu Ag PLATED
2	CONTACT FOOT	1	PHOSPHOR BRONZE	MB:Cu Ag PLATED
1	HOUSING	1	PA9T	
LTR	PART NAME	QTY	MATERIAL	REMARK

GENAL TOLERANCE ± 0.2	DRAW M. C. WANG	PART NO SEAR12-062X-X-A/B/C-X
	DESIGN H. D. LI	TITLE 2.5MM MINIATURE JACK (SMT)
	CHECKED Y. M. LU	
UNIT :mm	APPROVED J. F. KANG	宏揚精密有限公司 HOJAR PRECISION CO., LTD.