

ORDER INFORMATION:

SEAR12 - 065 $\frac{X}{a}$ - $\frac{X}{b}$ - $\frac{A/B/C}{c}$ - $\frac{X}{d}$

- a. SCHEMATIC:
A~C
- b. Post selection:
1: with post
- c. Length/Width/Height:
A/B/C (A=12.0,B=5.0,C=3.2) (standard)
- d. Pack selection:
R:Reel Pack

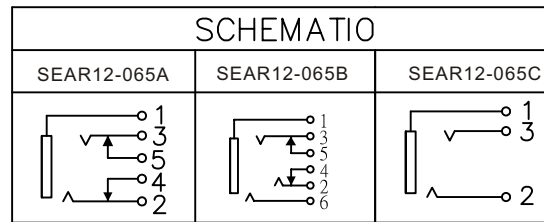
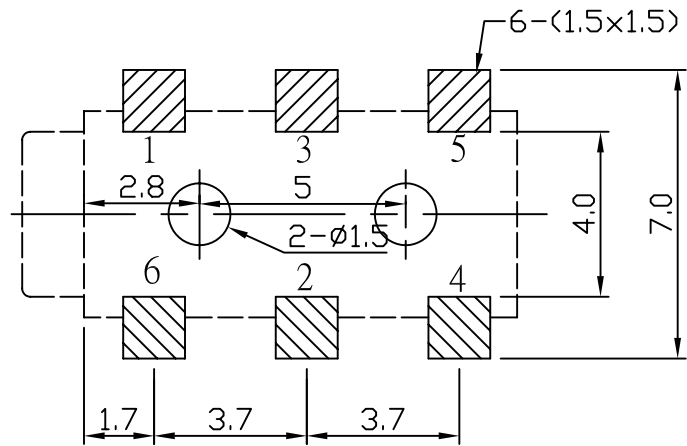

T:1.6 Dimensions of PC board holes
Tolerance : ± 0.1 (Printed-top view)

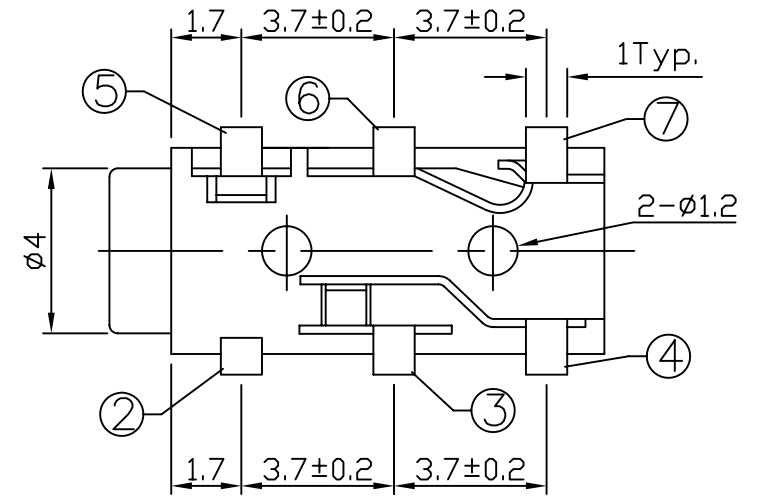
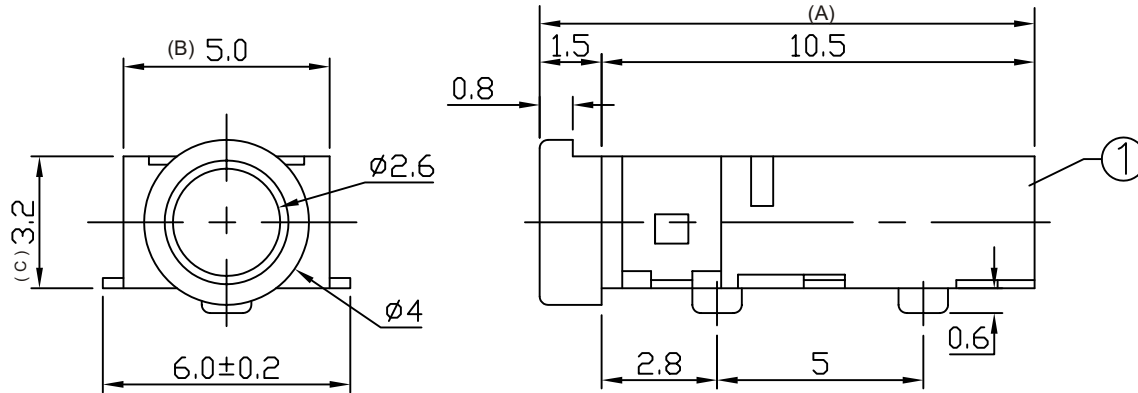

7	CURVE PIECE	1	BRASS	MB:Cu Au PLATED
6	SPRING	1	BRONZE	MB:Cu Au PLATED
5	CONTACT FOOT	1	BRONZE	MB:Cu Au PLATED
4	CURVE PIECE	1	BRASS	MB:Cu Au PLATED
3	SPRING	1	BRONZE	MB:Cu Au PLATED
2	CONTACT FOOT	1	BRONZE	MB:Cu Au PLATED
1	HOUSING	1	PA9T	
LTR	PART NAME	QTY	MATERIAL	REMARK

GENAL TOLERANCE ± 0.2	DRAW M. C. WANG	PART NO SEAR12-065X-X-A/B/C-X
	DESIGN H. D. LI	TITLE 2.5MM MINIATURE JACK (SMT)
	CHECKED Y. M. LU	
	APPROVED J. F. KANG	
UNIT :mm		宏揚精密有限公司 HOJAR PRECISION CO., LTD.