

ORDER INFORMATION:

SEAR12 - 066X - X - A/B/C - X
 a b c d

- a. SCHEMATIC:
A~B
- b. Post selection:
1: with post
- c. Length/Width/Height:
A/B/C (A=14.6,B=7.1,C=3.4) (standard)
- d. Pack selection:
R:Reel Pack

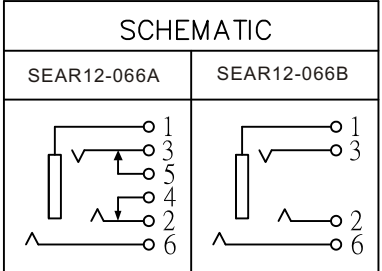
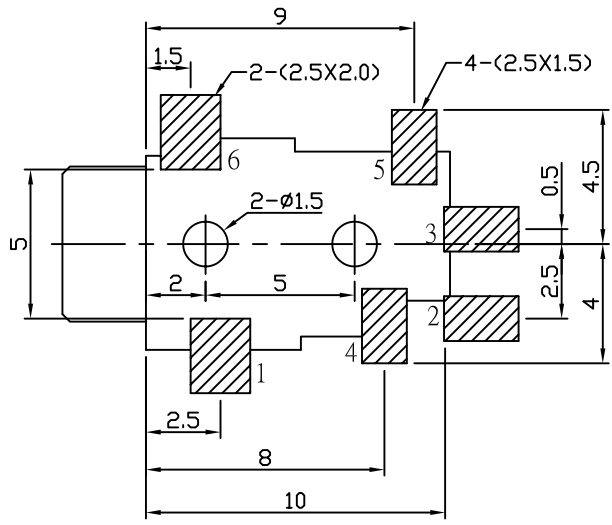

T:1.6 Dimensions of PC board holes
 Tolerance : ±0.1(Printed-top view)

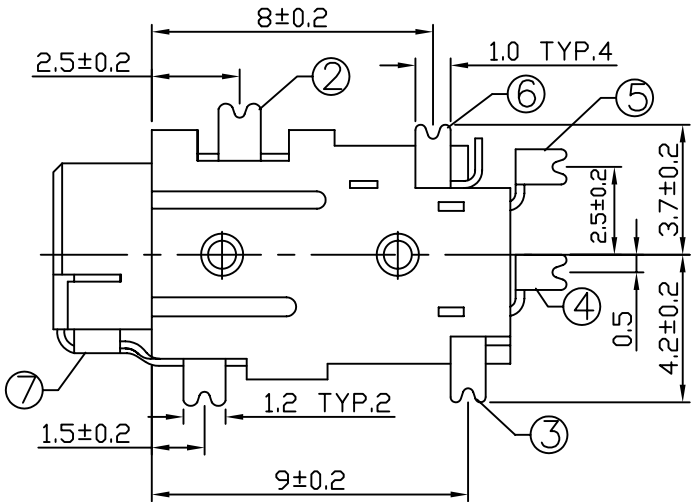
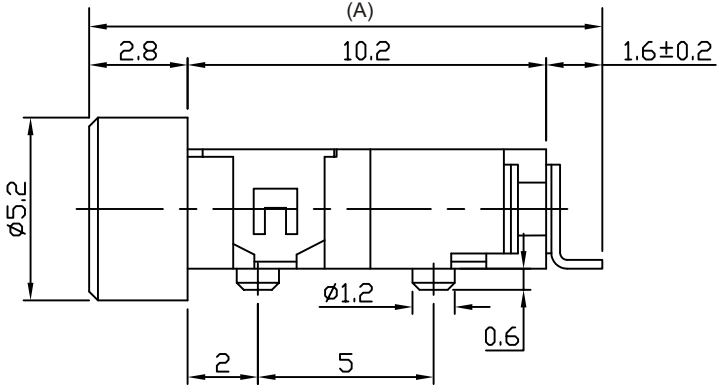
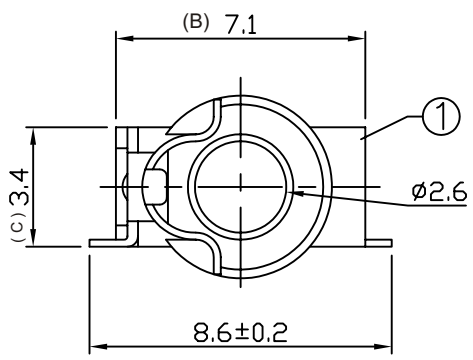

| | | | | |
|-----|--------------|-----|-----------------|---------------------|
| 7 | CONTACT FOOT | 1 | BRASS | MB:Cu Au(Ag) PLATED |
| 6 | SPRING PIECE | 1 | PHOSPHOR BRONZE | MB:Cu Au(Ag) PLATED |
| 5 | CONTACT FOOT | 1 | BRASS | MB:Cu Au(Ag) PLATED |
| 4 | CONTACT FOOT | 1 | BRASS | MB:Cu Au(Ag) PLATED |
| 3 | SPRING PIECE | 1 | PHOSPHOR BRONZE | MB:Cu Au(Ag) PLATED |
| 2 | CONTACT FOOT | 1 | PHOSPHOR BRONZE | MB:Cu Au(Ag) PLATED |
| 1 | HOUSING | 1 | PA9T | |
| LTR | PART NAME | QTY | MATERIAL | REMARK |

| | | |
|--------------------------|------------------------|---------------------------------------|
| GENAL TOLERANCE ± 0.2 | DRAW M. C. WANG | PART NO SEAR12-066X-X-A/B/C-X |
| | DESIGN H. D. LI | TITLE 2.5MM MINIATURE JACK (SMT) |
| | CHECKED Y. M. LU | |
| | APPROVED J. F. KANG | |
| UNIT :mm | | 宏揚精密有限公司 HOJAR PRECISION CO., LTD. |