

ORDER INFORMATION:

SEAR12 - 043X - X - A/B/C - X
 $\frac{a}{b} \frac{c}{d}$

- a. SCHEMATIC:
A~B
- b. Post selection:
1: with post
- c. Length/Width/Height:
A/B/C (A=11.5, B=5.0, C=3.2) (standard)
- d. Pack selection:
R: Reel Pack

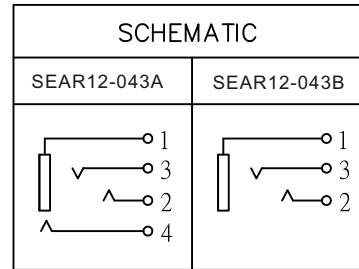
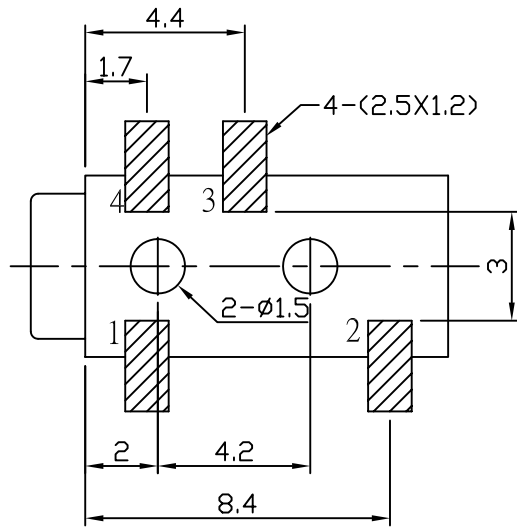

T:1.6 Dimensions of PC board holes
 Tolerance : ±0.1(Printed-top view)

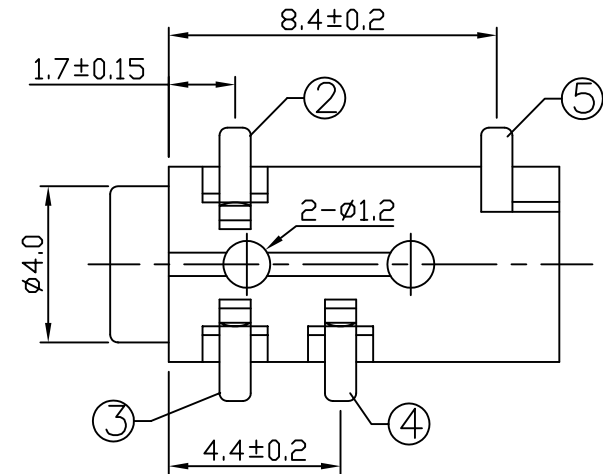
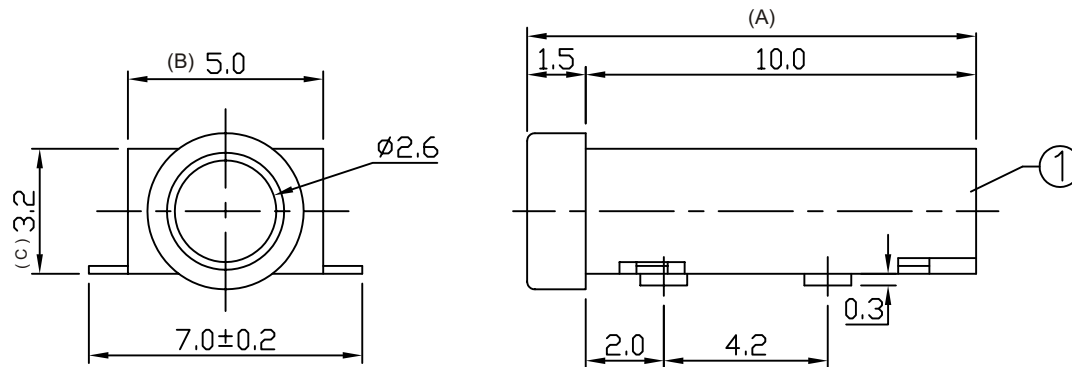

5	SPRING	1	BRASS	MB:Cu Au(Ag) PLATED
4	CONTACT FOOT	1	BRASS	MB:Cu Au(Ag) PLATED
3	CONTACT FOOT	1	PHOSPHOR BRONZE	MB:Cu Au(Ag) PLATED
2	CONTACT FOOT	1	PHOSPHOR BRONZE	MB:Cu Au(Ag) PLATED
1	HOUSING	1	PA9T	
LTR	PART NAME	QTY	MATERIAL	REMARK

GENAL TOLERANCE ± 0.2	DRAW	M. C. WANG	PART NO	SEAR12-043X-X-A/B/C-X
	DESIGN	H. D. LI	TITLE	2.5MM MINIATURE JACK (SMT)
	CHECKED	Y. M. LU		
	APPROVED	J. F. KANG		
UNIT :mm				宏揚精密有限公司 HOJAR PRECISION CO., LTD.