

# ORDER INFORMATION:

EAR13- 091 $\overline{X}$  - $\overline{X}$   $\overline{X}$  -  $\frac{A}{d}$ / $\frac{B}{c}$  -  $\frac{X}{e}$

- a. SCHEMATIC:  
A~K
- b. Post selection:  
1: with post
- c. Color:  
B: Black
- d. Length/Width/Height:  
A/B/C (A=18.0,B=12.9,C=10.3) (standard)
- e. Pack selection:  
D:Disk Pack

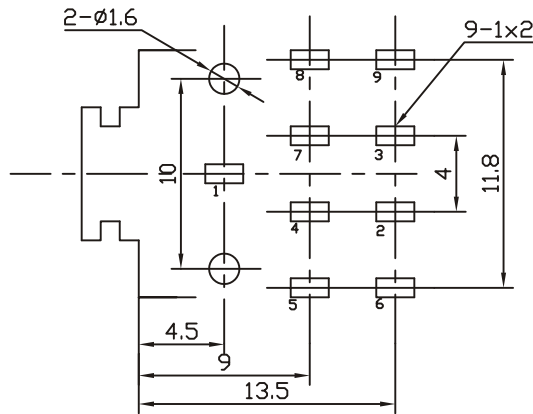

T:1.6 Dimensions of PC board holes  
Tolerance : ±0.1(Printed-top view)

SCHEMATIC			
MODEL NO	EAR13-091A	EAR13-091B	EAR13-091C
SCHEMATIC			
EAR13-091D	EAR13-091E	EAR13-091F	EAR13-091G
EAR13-091H	EAR13-091I	EAR13-091J	EAR13-091K

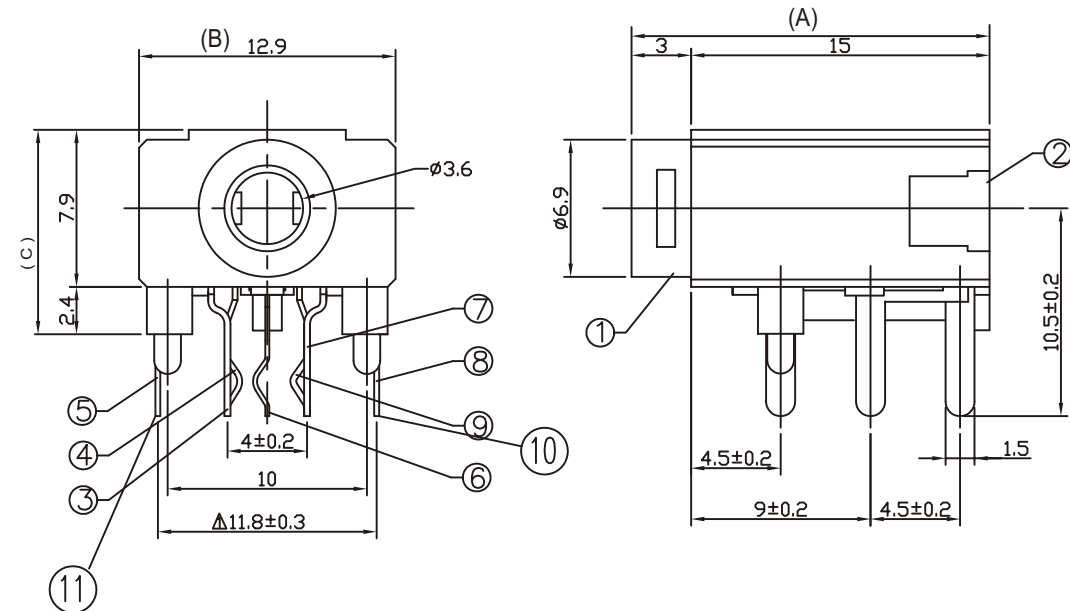

11	CONTACT FOOT	1	BRONZE	MB:Cu Ag PLATED
10	CONTACT FOOT	1	BRONZE	MB:Cu Ag PLATED
9	CONTACT FOOT	1	BRASS	MB:Cu Ag PLATED
8	SPRING PIECE	1	BRONZE	MB:Cu Ag PLATED
7	CURVE PIECE	1	BRASS	MB:Cu Ag PLATED
6	CONTACT FOOT	1	BRASS	MB:Cu Ag PLATED
5	SPRING PIECE	1	BRONZE	MB:Cu Ag PLATED
4	CONTACT FOOT	1	BRASS	MB:Cu Ag PLATED
3	CURVE PIECE	1	BRASS	MB:Cu Ag PLATED
2	COVER	1	POM	
1	HOUSING	1	PBT	
LTR	PART NAME	QTY	MATERIAL	REMARK

GENAL TOLERANCE ±0.3	DRAW M. C. WANG	PART NO EAR13-091X-XX-A/B/C-X
	DESIGN H. D. LI	TITLE 3.5mm MINIATURE JACK (DIP)
	CHECKED Y. M. LU	宏揚精密有限公司 HOJAR PRECISION CO., LTD.
UNIT :mm	APPROVED J. F. KANG	