

ORDER INFORMATION:

SEAR13- 044X -X - A/B/C - X
 $\frac{\quad}{a} \frac{\quad}{b} \frac{\quad}{c} \frac{\quad}{d}$

- a. SCHEMATIC:
A、B、C
- b. Post selection:
1: with post
- c. Length/Width/Height:
A/B/C (A=14.0,B=6.0,C=5.0) (standard)
- d. Pack selection:
R:Reel Pack

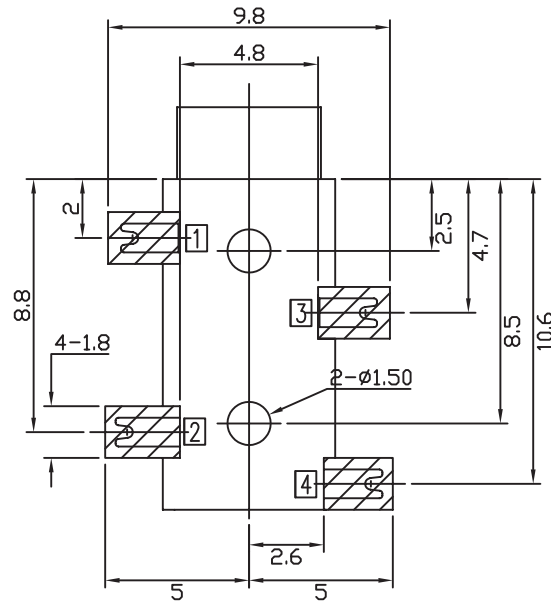
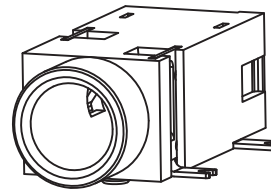

Recommended PCB Layout
 Tolerance: ±0.1(Printed-side view)

SCHEMATIC		
SEAR13-044A	SEAR13-044B	SEAR13-044C

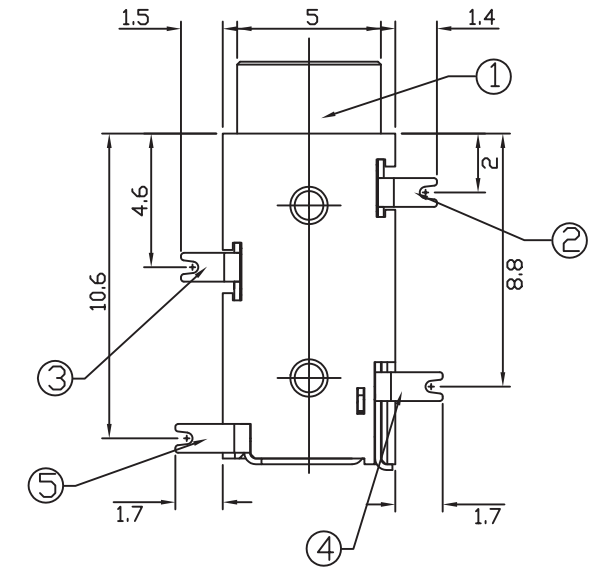
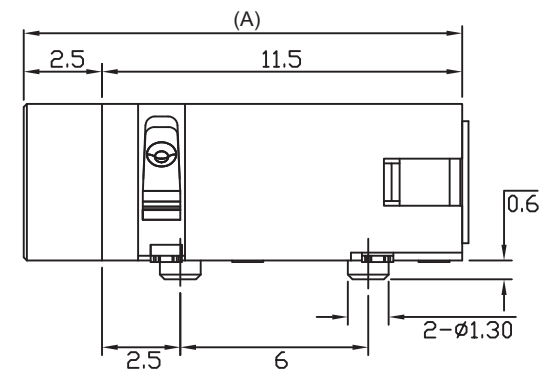
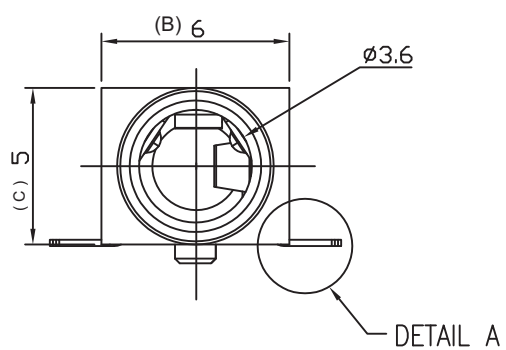

5	BREAK TERMINAL	1	C2680 t=0.2	MB : Cu Ag PLATED
4	TIP SPRING	1	C2680 t=0.2	MB : Cu Ag PLATED
3	RING SPRING	1	C5210 t=0.2	MB : Cu Ag PLATED
2	EARTH SPRING	1	C5210 t=0.2	MB : Cu Ag PLATED
1	HOUSING	1	PA9T	UL-94V-0
LTR	PART NAME	QTY	MATERIAL	REMARK

GENAL TOLERANCE ± 0.2	DRAW M. C. WANG	PART NO SEAR13-044X-X-A/B/C-X
	DESIGN H. D. LI	TITLE 3.5mm MINIATURE JACK (SMT)
	CHECKED Y. M. LU	
	APPROVED J. F. KANG	
UNIT :mm		宏揚精密有限公司 HOJAR PRECISION CO., LTD.