

ORDER INFORMATION:

SEAR13- 055X -X - A/B/C - X
 $\frac{a}{b} \frac{c}{d}$

a. SCHEMATIC:

A

b. Post selection:

1: with post

c. Length/Width/Height:

A/B/C (A=14.0,B=6.5,C=5.0) (standard)

d. Pack selection:

R:Reel Pack

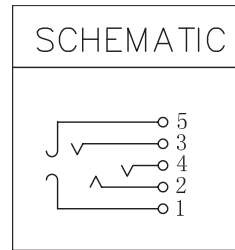
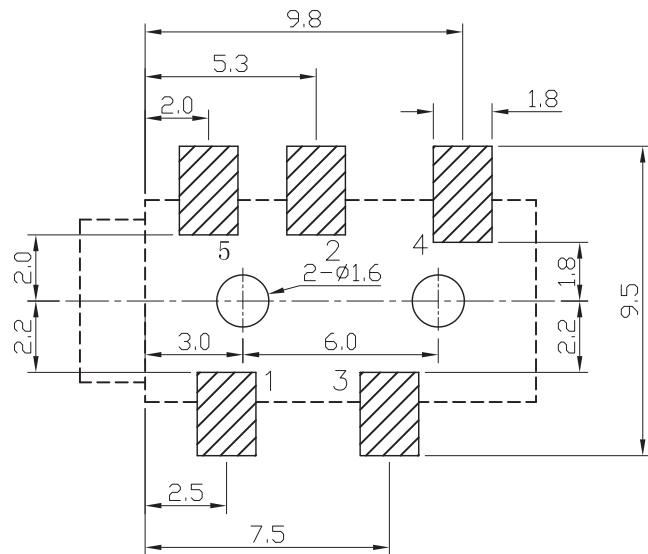

T:1.6 Dimensions of PC board holes
 Tolerance : ± 0.1 (Printed-top view)

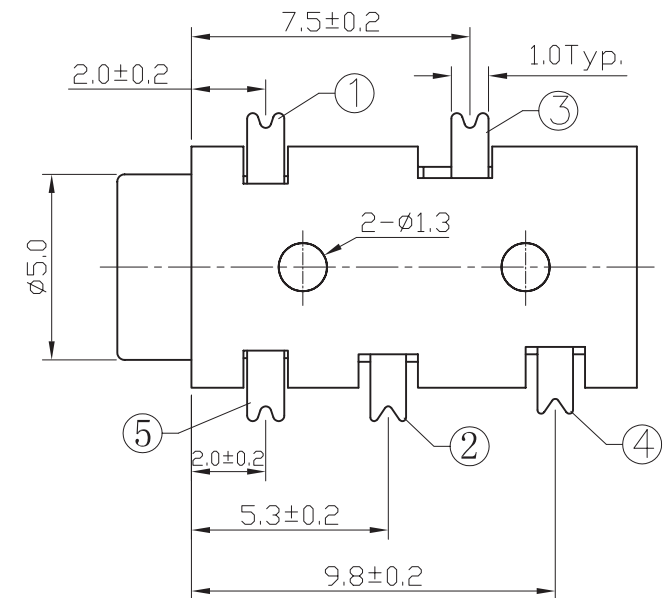
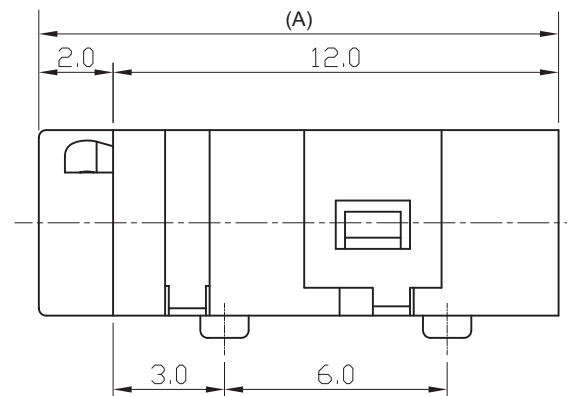
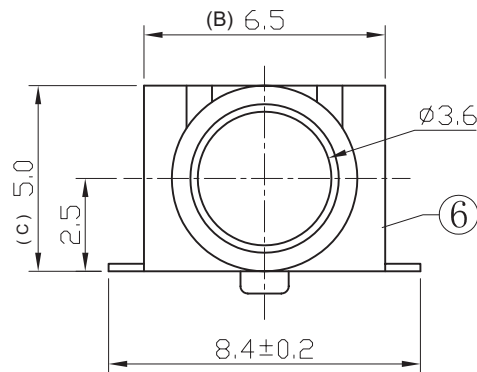

6	HOUSING	1	PA9T	
5	SPRING	1	PHOSPHOR BRONZE	MB:Cu Ag PLATED
4	CONTACT FOOT	1	PHOSPHOR BRONZE	MB:Cu Ag PLATED
3	SPRING	1	PHOSPHOR BRONZE	MB:Cu Ag PLATED
2	CONTACT FOOT	1	PHOSPHOR BRONZE	MB:Cu Ag PLATED
1	SPRING	1	PHOSPHOR BRONZE	MB:Cu Ag PLATED
LTR	PART NAME	QTY	MATERIAL	REMARK

GENAL TOLERANCE ± 0.2	DRAW M. C. WANG	PART NO SEAR13-055X-X-A/B/C-X
	DESIGN H. D. LI	TITLE 3.5mm MINIATURE JACK (SMT)
	CHECKED Y. M. LU	
	APPROVED J. F. KANG	
UNIT :mm		 宏揚精密有限公司 HOJAR PRECISION CO., LTD.